

VB-1W Series

1W2:1 Regulated Single & Dual output



Features

- 8 Pin SIL / 16 Pin DIL
- Wide 2:1 Input Range
- Full SMD Technology
- 1000 VDC Isolation, Up to 3000 VDC
- Continuous Short Circuit Protection
- Efficiency up to 77%
- -40°C ~ 85°C Operation Temperature Range
- Plastic Case Standard, Optional Metal Case
- Remote on/off Control (Optional)



The VB series is a family of cost effective 1W single & dual output DC-DC converters. These converters combine non-conductive black plastic case in a 8-pin SIL / 16-pin DIL package with high performance features such as 1000Vdc~3000Vdc input/output isolation voltage, continuous short circuit protection with automatic restart and high line / load regulation. Devices are encapsulated using flame retardant resin. Input voltages of 5,12,24 and 48 with output voltage of 3.3, 5.9, 12, 15, 24, ±3.3, ±5, ±9, ±12, ±15, ±24 Vdc. High performance features include high efficiency operation up to 77% and output voltage accuracy of ±2% maximum.

All specifications typical at Ta=25°C, nominal input voltage and full load unless otherwise specified

OUTPUT SPECIFICATIONS	
Voltage Accuracy	±2%
Maximum Output Current	See table
Line Regulation	±0.5%,max.
Load Regulation	(From 25% to 100% Loading) ±1%,max.
Cross Regulation (Dual Output) (4)	±5%
Ripple & Noise (20 Mhz bandwidth)(5)	80mVpp,max.
Short Circuit Protection	Indefinite (Automatic Recovery)
Temperature Coefficient	±0.02%/°C
Capacitive Load(6)	See table

INPUT SPECIFICATIONS	
Voltage Range	See table
Max. Input Current	See table
No-Load Input Current	See table
Input Filter	Capacitor
Input Reflected Ripple Current(7)	35mA pk-pk

ENVIRONMENT SPECIFICATIONS	
Operating Temperature	-40°C~85°C(See Derating Curve)
Maximum Case Temperature	100°C
Storage Temperature	-40°C~125°C
Cooling	Nature Convection

ABSOLUTE MAXIMUM RATINGS(8)	
These are stress ratings. Exposure of devices to any of these conditions may adversely affect long-term reliability.	
Input Surge Voltage(100ms max.)	
05 Models	12Vdc,max.
12 Models	24Vdc,max.
24 Models	40Vdc,max.
48 Models	80Vdc,max.
Soldering Temperature (1.5mm from case 10 sec. max.)	260°C max.

GENERAL SPECIFICATIONS	
Efficiency	See table
I/O Isolation Voltage (60 sec)	1000~3000Vdc
Metal Case/Input & Output	1000Vdc
I/O Isolation Capacitance	60 pF,max.
I/O Isolation Resistance	1000M Ohm,min.
Switching Frequency	100~650kHz
Humidity	95%reIH
Reliability Calculated MTBF(MIL-HDBK-217 F)	>1.66 Mhrs
Safety Standard : (designed to meet)	IEC/EN 60950-1
Remote On/Off (CTRL) (11)	

PHYSICAL SPECIFICATIONS	
Case Material	Non-conductive Black Plastic(UL94V-0 rated) Nickel-coated Copper
Pin Material	
SIP Case	Alloy42 Solder-coated
DIP Case	Φ0.5mm Brass Solder-coated
Potting Material	Epoxy (UL94V-0 rated)
Weight	4.5g(SIP)~6g(DIP) Metal Case/6.5g(SIP)~8g(DIP)
Dimensions	
SIP Case	0.86"x0.36"x0.44"
DIP Case	0.92"x0.55"x0.40"

EMC SPECIFICATIONS		
Radiated Emissions	EN55022	CLASS A
Conducted Emissions (12)	EN55022	CLASS A
ESD	IEC 61000-4-2	Perf. Criteria B
RS	IEC 61000-4-3	Perf. Criteria A
EFT (13)	IEC 61000-4-4	Perf. Criteria B
Surge (13)	IEC 61000-4-5	Perf. Criteria B
CS	IEC 61000-4-6	Perf. Criteria A
PFMF	IEC 61000-4-8	Perf. Criteria A

The information and specifications contained in this data sheet are believed to be correct at time of publication. However, MOTIEN Technologies accepts no responsibility for consequences arising from printing errors or inaccuracies. Specifications are subject to change without notice. No rights under any patent accompany the sale of any such product(s) or information contained herein.

VB - 1W 2:1 Regulated Single & Dual output

PART NUMBER STRUCTURE

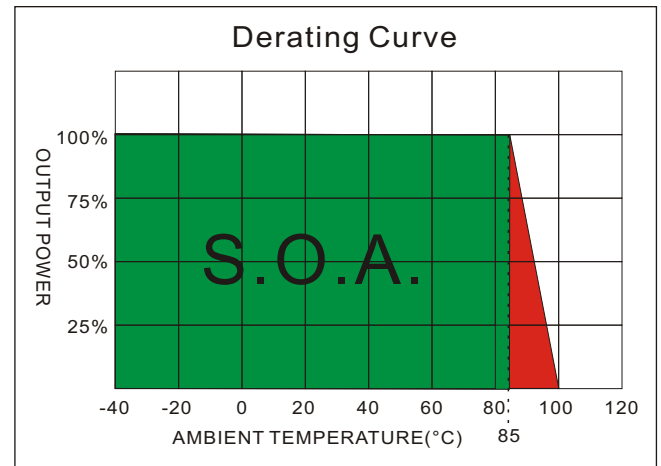
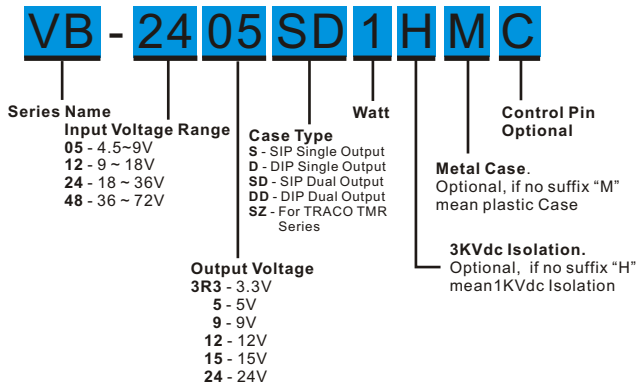

MODEL SELECTION GUIDE

MODEL NUMBER	INPUT Voltage Range (Vdc)	INPUT Current		OUTPUT Voltage (Vdc)	OUTPUT Current		EFFICIENCY @FL(%)	Capacitor Load(μF)
		No-Load (mA)	Full Load (mA)		Min. load (mA)	Full load (mA)		
VB-053R3S1	4.5-9	15	298	3.3	76	303	67	3300
VB-0505S1	4.5-9	15	298	5	50	200	67	3300
VB-0509S1	4.5-9	40	285	9	28	111	70	470
VB-0512S1	4.5-9	55	285	12	21	83	70	470
VB-0515S1	4.5-9	55	285	15	17	67	70	470
VB-0524S1	4.5-9	70	294	24	10	42	68	220
VB-123R3S1	9-18	15	119	3.3	76	303	70	3300
VB-1205S1	9-18	15	115	5	50	200	72	3300
VB-1209S1	9-18	15	108	9	28	111	77	470
VB-1212S1	9-18	15	108	12	21	83	77	470
VB-1215S1	9-18	15	108	15	17	67	77	470
VB-1224S1	9-18	15	114	24	10	42	73	220
VB-243R3S1	18-36	8	59	3.3	76	303	70	3300
VB-2405S1	18-36	8	57	5	50	200	72	3300
VB-2409S1	18-36	8	55	9	28	111	75	470
VB-2412S1	18-36	8	55	12	21	83	75	470
VB-2415S1	18-36	8	55	15	17	67	75	470
VB-2424S1	18-36	8	55	24	10	42	75	220
VB-483R3S1	36-72	6	31	3.3	76	303	66	3300
VB-4805S1	36-72	6	30	5	50	200	68	3300
VB-4809S1	36-72	6	29	9	28	111	70	470
VB-4812S1	36-72	6	29	12	21	83	70	470
VB-4815S1	36-72	6	29	15	17	67	70	470
VB-4824S1	36-72	6	30	24	10	42	68	220
VB-053R3D1	4.5-9	15	298	3.3	76	303	67	3300
VB-0505D1	4.5-9	15	298	5	50	200	67	3300
VB-0509D1	4.5-9	40	285	9	28	111	70	470
VB-0512D1	4.5-9	55	285	12	21	83	70	470
VB-0515D1	4.5-9	55	285	15	17	67	70	470
VB-0524D1	4.5-9	70	294	24	10	42	68	220
VB-123R3D1	9-18	15	119	3.3	76	303	70	3300
VB-1205D1	9-18	15	115	5	50	200	72	3300
VB-1209D1	9-18	15	108	9	28	111	77	470
VB-1212D1	9-18	15	108	12	21	83	77	470
VB-1215D1	9-18	15	108	15	17	67	77	470
VB-1224D1	9-18	15	114	24	10	42	73	220

The models listed above is just for standard type. If you need the special specification product, please contact our service member by telephone presented in shortform cover or e-mail to : sales@motien.com.tw

VB - 1W 2:1 Regulated Single & Dual output

MODEL SELECTION GUIDE

MODEL NUMBER	INPUT Voltage Range (Vdc)	INPUT Current		OUTPUT Voltage (Vdc)	OUTPUT Current		EFFICIENCY @FL(%)	Capacitor Load(uF)
		No-Load (mA)	Full Load (mA)		Min. load (mA)	Full load (mA)		
VB-243R3D1	18-36	8	59	3.3	76	303	70	3300
VB-2405D1	18-36	8	57	5	50	200	72	3300
VB-2409D1	18-36	8	55	9	28	111	75	470
VB-2412D1	18-36	8	55	12	21	83	75	470
VB-2415D1	18-36	8	55	15	17	67	75	470
VB-2424D1	18-36	8	55	24	10	42	75	220
VB-483R3D1	36-72	6	31	3.3	76	303	66	3300
VB-4805D1	36-72	6	30	5	50	200	68	3300
VB-4809D1	36-72	6	29	9	28	111	70	470
VB-4812D1	36-72	6	29	12	21	83	70	470
VB-4815D1	36-72	6	29	15	17	67	70	470
VB-4824D1	36-72	6	30	24	10	42	68	220
VB-053R3SD1	4.5-9	15	285	±3.3	±38	±152	70	±1000
VB-0505SD1	4.5-9	15	270	±5	±25	±100	74	±1000
VB-0509SD1	4.5-9	20	270	±9	±14	±56	74	±220
VB-0512SD1	4.5-9	20	266	±12	±10	±42	75	±220
VB-0515SD1	4.5-9	40	285	±15	±8	±33	70	±220
VB-0524SD1	4.5-9	70	298	±24	±5	±21	67	±100
VB-123R3SD1	9-18	15	119	±3.3	±38	±152	70	±1000
VB-1205SD1	9-18	15	115	±5	±25	±100	72	±1000
VB-1209SD1	9-18	15	109	±9	±14	±56	76	±220
VB-1212SD1	9-18	15	109	±12	±10	±42	76	±220
VB-1215SD1	9-18	15	112	±15	±8	±33	74	±220
VB-1224SD1	9-18	40	124	±24	±5	±21	67	±100
VB-243R3SD1	18-36	8	59	±3.3	±38	±152	70	±1000
VB-2405SD1	18-36	8	59	±5	±25	±100	70	±1000
VB-2409SD1	18-36	8	54	±9	±14	±56	76	±220
VB-2412SD1	18-36	8	54	±12	±10	±42	77	±220
VB-2415SD1	18-36	8	55	±15	±8	±33	75	±220
VB-2424SD1	18-36	20	59	±24	±5	±21	70	±100
VB-483R3SD1	36-72	6	30	±3.3	±38	±152	70	±1000
VB-4805SD1	36-72	6	30	±5	±25	±100	70	±1000
VB-4809SD1	36-72	6	28	±9	±14	±56	74	±220
VB-4812SD1	36-72	6	27	±12	±10	±42	76	±220
VB-4815SD1	36-72	6	29	±15	±8	±33	72	±220
VB-4824SD1	36-72	12	30	±24	±5	±21	70	±100
VB-053R3DD1	4.5-9	15	285	±3.3	±38	±152	70	±1000
VB-0505DD1	4.5-9	15	270	±5	±25	±100	74	±1000
VB-0509DD1	4.5-9	20	270	±9	±14	±56	74	±220
VB-0512DD1	4.5-9	20	266	±12	±10	±42	75	±220
VB-0515DD1	4.5-9	40	285	±15	±8	±33	70	±220
VB-0524DD1	4.5-9	70	298	±24	±5	±21	67	±100
VB-123R3DD1	9-18	15	119	±3.3	±38	±152	70	±1000
VB-1205DD1	9-18	15	115	±5	±25	±100	72	±1000
VB-1209DD1	9-18	15	109	±9	±14	±56	76	±220
VB-1212DD1	9-18	15	109	±12	±10	±42	76	±220
VB-1215DD1	9-18	15	112	±15	±8	±33	74	±220
VB-1224DD1	9-18	40	124	±24	±5	±21	67	±100
VB-243R3DD1	18-36	8	59	±3.3	±38	±152	70	±1000
VB-2405DD1	18-36	8	59	±5	±25	±100	70	±1000

The models listed above is just for standard type. If you need the special specification product, please contact our service member by telephone presented in shortform cover or e-mail to : sales@motien.com.tw

VB - 1W 2:1 Regulated Single & Dual output

MODEL SELECTION GUIDE

MODEL NUMBER	INPUT Voltage Range (Vdc)	INPUT Current		OUTPUT Voltage (Vdc)	OUTPUT Current		EFFICIENCY @FL(%)	Capacitor Load(uF)
		No-Load (mA)	Full Load (mA)		Min. load (mA)	Full load (mA)		
VB-2409DD1	18-36	8	54	±9	±14	±56	76	±220
VB-2412DD1	18-36	8	54	±12	±10	±42	77	±220
VB-2415DD1	18-36	8	55	±15	±8	±33	75	±220
VB-2424DD1	18-36	20	59	±24	±5	±21	70	±100
VB-483R3DD1	36-72	6	30	±3.3	±38	±152	70	±1000
VB-4805DD1	36-72	6	30	±5	±25	±100	70	±1000
VB-4809DD1	36-72	6	28	±9	±14	±56	74	±220
VB-4812DD1	36-72	6	27	±12	±10	±42	76	±220
VB-4815DD1	36-72	6	29	±15	±8	±33	72	±220
VB-4824DD1	36-72	12	30	±24	±5	±21	70	±100

Suffix "H" means 3KVdc isolation

Suffix "C" means with control pin

Suffix "M" means with Metal Case

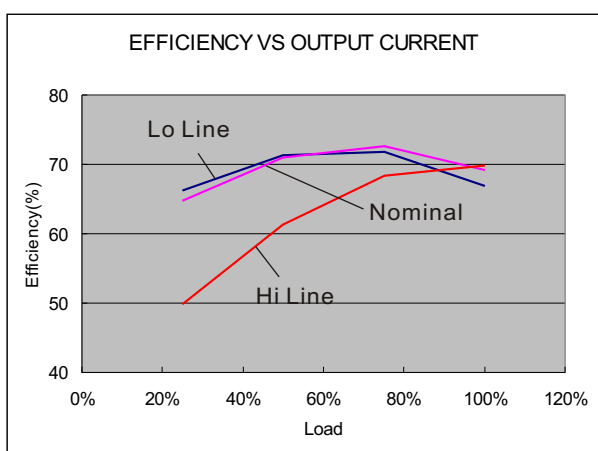

05 Models

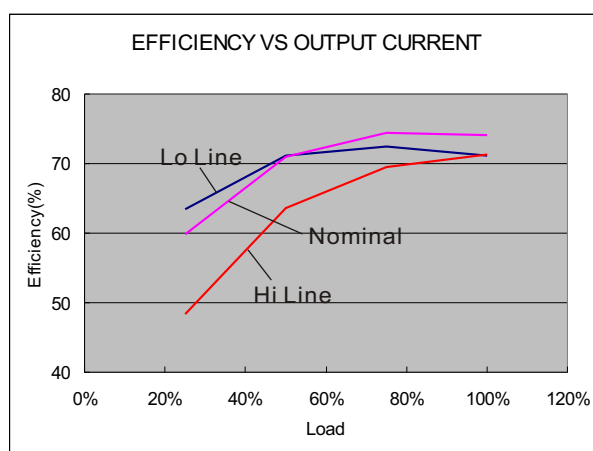

12 Models

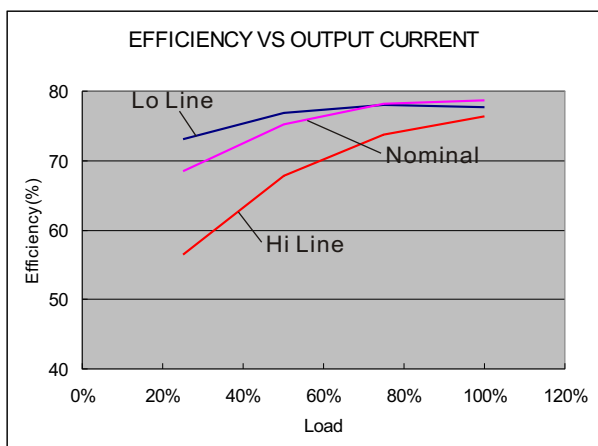

24 Models

NOTE

1. Maximum value at nominal input voltage and full load.
2. Typical value at nominal input voltage and full load.
3. 25% minimum loading is needed.
4. One load is 25% to 100% load, the other load is 100% load, the output voltage variable rate is within ±5%.
5. Ripple/Noise measured with 20MHz bandwidth.
6. Test by nominal input voltage and constant resistor load.
7. Measured Input reflected ripple current with a simulated source inductance of 12uH.
8. Exceeding the absolute ratings of the unit could cause damage. It is not allowed for continuous operating.
9. Operation under no-load conditions will not damage these devices, however they may not meet all listed specifications.
10. It's necessary to add minimum capacitor in output for some models, please check single model datasheet for detail value.

The models listed above is just for standard type. If you need the special specification product, please contact our service member by telephone presented in shortform cover or e-mail to : sales@motien.com.tw

NOTE

11. MCU (Master Control Unit)

The MCU Pin Voltage is referenced to -Vin(Pin 1)

ON:0 ~ 0.8VDC Max.

(Short circuit Pin 1 and Pin 3) or open circuit

OFF:4.5 to 15VDC Max.(or 3.5mA to 15mA Max.)(via R1 、 D1)

OFF idle current:5mA typ.

Connection example



12. Input filter components are be required to help meet conducted emission class A, which application refer to the EMI Filter of design & test configuration.

13. An external filter capacitor is required if the module has to meet IEC61000-4-4 and IEC61000-4-5. The filter capacitor Motien suggest: Nippon - chemi - con KY series, 220uF/100V.

TEST CONFIGURATIONS

Input Reflected Ripple Current Test Step

Input reflected ripple current is measured through a source inductor Lin(12uH) and a source capacitor Cin(47uF, ESR<1.0Ω at 100KHz) at nominal input and full load.

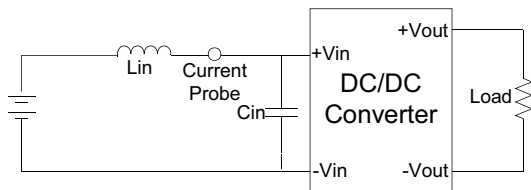

Output Ripple & Noise Measurement Test

The Scope measurement bandwidth is 20MHz.

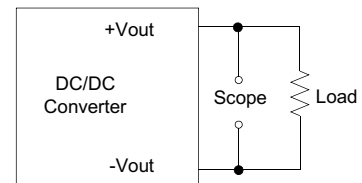

EMI Filter

Input filter components (C1, L) are used to help meet conducted emissions requirement for the module. These components should be mounted as close as possible to the module; and all leads should be minimized to decrease radiated noise.

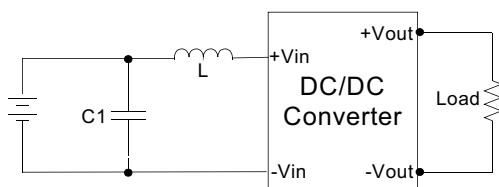

	C1	L
VB-1W&2W-Series	100uF/100V	12uH

MECHANICAL SPECIFICATIONS

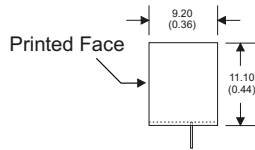
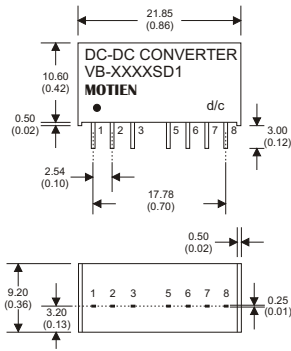

8 Pin SIL Package
Non-Conductive Plastic

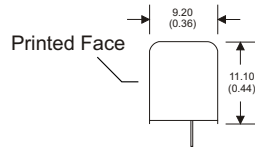
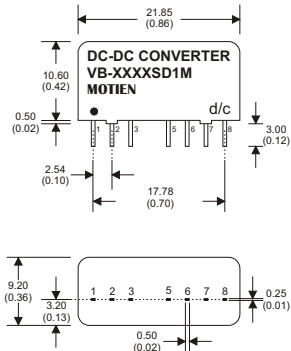

8 Pin SIL Package
Nickel-Coated Copper

Notes: All dimensions are typical in millimeters (inches).
 1. Pin diameter: 0.5 ±0.05 (0.02 ±0.002)
 2. Pin pitch and length tolerance: ±0.35 (±0.014)
 3. Case Tolerance: ±0.5 (±0.02)

PIN CONNECTIONS			
PIN NUMBER	SINGLE	DUAL/(SD)	DUAL/(SZ)
1	-V Input	-V Input	-V Input
2	+V Input	+V Input	+V Input
3	N.P.	N.C.	N.C.
5	N.P.	N.C.	N.C.
6	+V Output	+V Output	+V Output
7	-V Output	-V Output	Common
8	N.C.	Common	-V Output
PIN NUMBER	SINGLE+C	DUAL/(SD+C)	DUAL/(SZ+C)
1	-V Input	-V Input	-V Input
2	+V Input	+V Input	+V Input
3	Remote On/Off	Remote On/Off	Remote On/Off
5	N.C.	N.C.	N.C.
6	+V Output	+V Output	+V Output
7	-V Output	-V Output	Common
8	N.C.	Common	-V Output

(The Pin Connection of high isolation one is the same with normal one.)

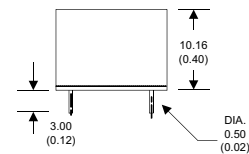
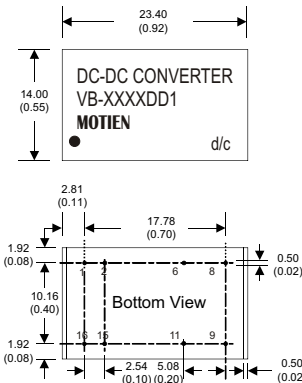

16 Pin DIL Package
Non-Conductive Plastic

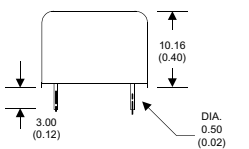
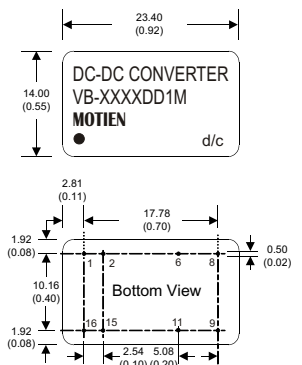

16 Pin DIL Package
Nickel-Coated Copper

PIN CONNECTIONS		
PIN NUMBER	SINGLE	DUAL
1	-V Input	-V Input
2	-V Input	-V Input
6	N.C.	Common
8	N.C.	-V Output
9	+V Output	+V Output
11	-V Output	Common
15	+V Input	+V Input
16	+V Input	+V Input

(The Pin Connection of high isolation one is the same with normal one.)