

VG-1.5W Series



1.5W 2:1 Regulated Single & Dual output

Features

- Wide 2:1 Input Range
- Full SMD Technology
- 1500 VDC Isolation, Up to 3500 VDC
- Continuous Short Circuit Protection
- Efficiency up to 75%
- -40 ~ 85°C Operation Temperature Range
- Metal Case Standard, Optional Plastic Case



The VG series is a family of cost effective 1.5W single & dual output DC-DC converters. These converters are consisted with Nickel-coated copper in a 24-pin DIL package with high performance features such as 1500 VDC ~ 3500VDC input/output isolation voltage, continuous short circuit protection with automatic restart and tight line / load regulation. Devices are encapsulated using flame retardant resin. Input voltages of 12,24 and 48 with output voltage of 3.3,5,9,12,15, 24, ±3.3, ±5, ±9, ±12, ±15 and ±24 Vdc. High performance features include high efficiency operation up to 75% and output voltage accuracy of ±1% maximum.

All specifications typical at Ta=25°C, nominal input voltage and full load unless otherwise specified

OUTPUT SPECIFICATIONS	
Voltage accuracy	±1%
Line regulation	±0.5%
Load regulation	±0.5%
	(Output 3.3V / ±3.3V Model) ±1.5%
Ripple & noise(20 MHz bandwidth)(1)	60mV pk-pk
Short circuit protection	Indefinite(Automatic Recovery)
Temperature coefficient	±0.02%/°C
Capacitor load(2)	See table

INPUT SPECIFICATIONS	
Voltage Range	See table
Max. Input Current	See table
No-Load Input Current	See table
Input Filter	PI Type
Input Reflected Ripple Current(3)	35mA pk-pk

GENERAL SPECIFICATIONS	
Efficiency	See table, typ.
I/O Isolation Voltage(3 sec)	
Input/Output	1500~3500Vdc
Metal Case/Input & Output	1000Vdc
I/O Isolation Capacitance	470 pF, typ.
I/O Isolation Resistance	1000M Ohm
Switching Frequency	266kHz, typ.
Humidity	95% rel H
Reliability Calculated MTBF(MIL-HDBK-217 F)	>1.121 Mhrs
Safety Standard : (designed to meet)	IEC 60950-1

PHYSICAL SPECIFICATIONS	
Case Material	Nickel-coated Copper
	Non-conductive Black Plastic(UL94V-0 rated)
Base Material	Non-conductive Black Plastic(UL94V-0 rated)
Pin Material	Ø0.5mm Brass Solder-coated
Potting Material	Epoxy (UL94V-0 rated)
Weight	17.0g(Metal Case)/13.5g(Plastic Case)
Dimensions	1.25"x0.8"x0.4"

ENVIRONMENT SPECIFICATIONS	
Operating Temperature	-40°C~85°C(See Derating Curve)
Maximum Case Temperature	100°C
Storage Temperature	-40°C~125°C
Cooling	Nature Convection

ABSOLUTE MAXIMUM RATINGS(4)	
These are stressratings. Exposure of devices to any of these conditions may adversely affect long-term reliability.	
Input Surge Voltage(100mS)	
12 Models	24 Vdc, max.
24 Models	40 Vdc, max.
48 Models	80 Vdc, max.
Soldering Temperature (1.5mm from case 10sec. max.)	260°C, max.

The information and specifications contained in this data sheet are believed to be correct at time of publication. However, MOTIEN Technologies accepts no responsibility for consequences arising from printing errors or inaccuracies. Specifications are subject to change without notice. No rights under any patent accompany the sale of any such product(s) or information contained herein.

VG - 1.5W 2:1 Regulated Single & Dual output

PART NUMBER STRUCTURE

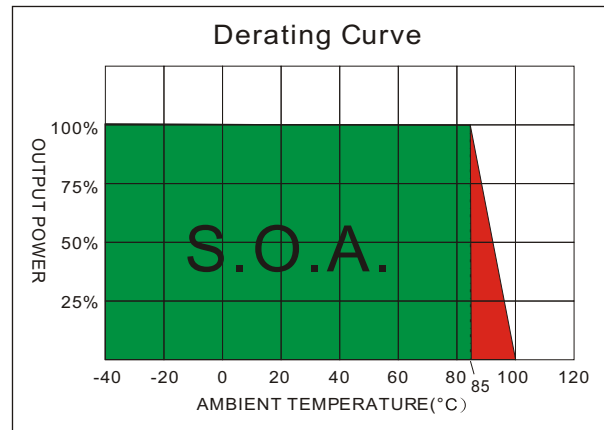
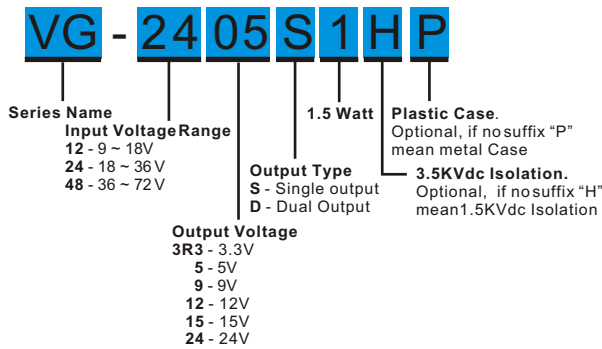

MODEL SELECTION GUIDE

MODEL NUMBER	INPUT Voltage Range (Vdc)	INPUT Current		OUTPUT Voltage (Vdc)	OUTPUT Current		EFFICIENCY @FL(%)	Capacitor Load(uF)
		No-Load (mA)	Full Load (mA)		Min. load (mA)	Full load (mA)		
VG-123R3S1	9-18	25	173	3.3	0	454	72	470
VG-1205S1	9-18	25	169	5	0	300	74	470
VG-1209S1	9-18	25	167	9	0	167	75	68
VG-1212S1	9-18	25	167	12	0	125	75	47
VG-1215S1	9-18	25	167	15	0	100	75	22
VG-1224S1	9-18	25	167	24	0	63	75	10
VG-123R3D1	9-18	25	173	±3.3	0	±227	72	±220
VG-1205D1	9-18	25	169	±5	0	±150	74	±220
VG-1209D1	9-18	25	167	±9	0	±84	75	±33
VG-1212D1	9-18	25	167	±12	0	±63	75	±22
VG-1215D1	9-18	25	167	±15	0	±50	75	±10
VG-1224D1	9-18	25	167	±24	0	±32	75	±10
VG-243R3S1	18-36	12	86	3.3	0	454	72	470
VG-2405S1	18-36	12	84	5	0	300	74	470
VG-2409S1	18-36	12	83	9	0	167	75	68
VG-2412S1	18-36	12	83	12	0	125	75	47
VG-2415S1	18-36	12	83	15	0	100	75	22
VG-2424S1	18-36	12	83	24	0	63	75	10
VG-243R3D1	18-36	12	86	±3.3	0	±227	72	±220
VG-2405D1	18-36	12	84	±5	0	±150	74	±220
VG-2409D1	18-36	12	83	±9	0	±84	75	±33
VG-2412D1	18-36	12	83	±12	0	±63	75	±22
VG-2415D1	18-36	12	83	±15	0	±50	75	±10
VG-2424D1	18-36	12	83	±24	0	±32	75	±10
VG-483R3S1	36-72	8	43	3.3	0	454	72	470
VG-4805S1	36-72	8	42	5	0	300	74	470
VG-4809S1	36-72	8	42	9	0	167	74	68
VG-4812S1	36-72	8	42	12	0	125	74	47
VG-4815S1	36-72	8	42	15	0	100	74	22
VG-4824S1	36-72	8	42	24	0	63	74	10

Suffix "H" means 3.5KVdc isolation

Suffix "P" means Plastic case instead of standard Metal Case

VG - 1.5W 2:1 Regulated Single & Dual output

MODEL NUMBER	INPUT Voltage Range (Vdc)	INPUT Current		OUTPUT Voltage (Vdc)	OUTPUT Current		EFFICIENCY @FL(%)	Capacitor Load(uF)
		No-Load (mA)	Full Load (mA)		Min. load (mA)	Full load (mA)		
VG-483R3D1	36-72	8	43	±3.3	0	±227	72	±220
VG-4805D1	36-72	8	42	±5	0	±150	74	±220
VG-4809D1	36-72	8	42	±9	0	±84	74	±33
VG-4812D1	36-72	8	42	±12	0	±63	74	±22
VG-4815D1	36-72	8	42	±15	0	±50	74	±10
VG-4824D1	36-72	8	42	±24	0	±32	74	±10

Suffix "H" means 3.5KVdc isolation

Suffix "P" means Plastic case instead of standard Metal Case

NOTE

1. Ripple/Noise measured with a 1uF ceramic capacitor.
2. Test by nominal input voltage and constant resistor load.
3. Measured Input reflected ripple current with a simulated source inductance of 12uH.
4. Exceeding the absolute ratings of the unit could cause damage. It is not allowed for continuous operating.

TEST CONFIGURATIONS

Input Reflected Ripple Current Test Step

Input reflected ripple current is measured through a source inductor L_{in} (12uH) and a source capacitor C_{in} (47uF, ESR<1.0Ω at 100KHz) at nominal input and full load.

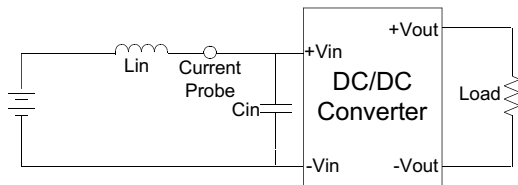

Output Ripple & Noise Measurement Test

Use a capacitor C_{out} (1.0uF) measurement. The Scope measurement bandwidth is 0-20MHz.

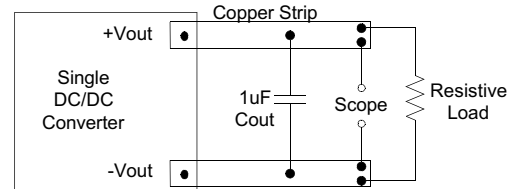

ELECTRICAL CHARACTERISTIC CURVES

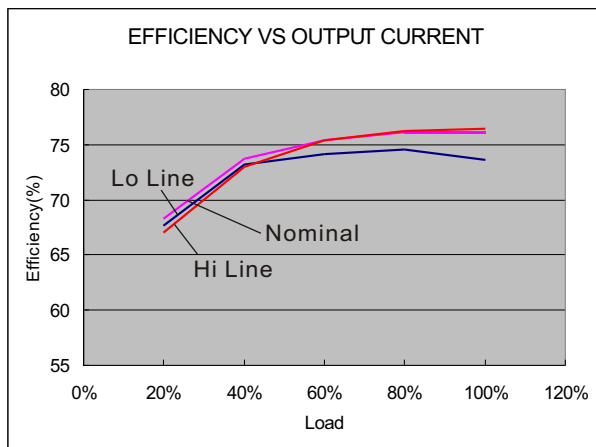

12 Models

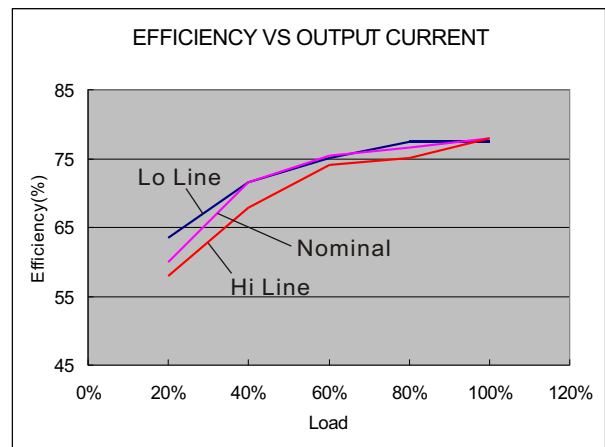

24 Models

VG - 1.5W 2:1 Regulated Single & Dual output

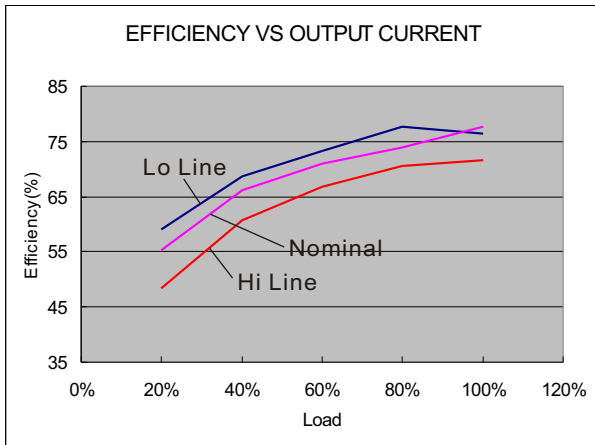

48 Models

MECHANICAL SPECIFICATIONS

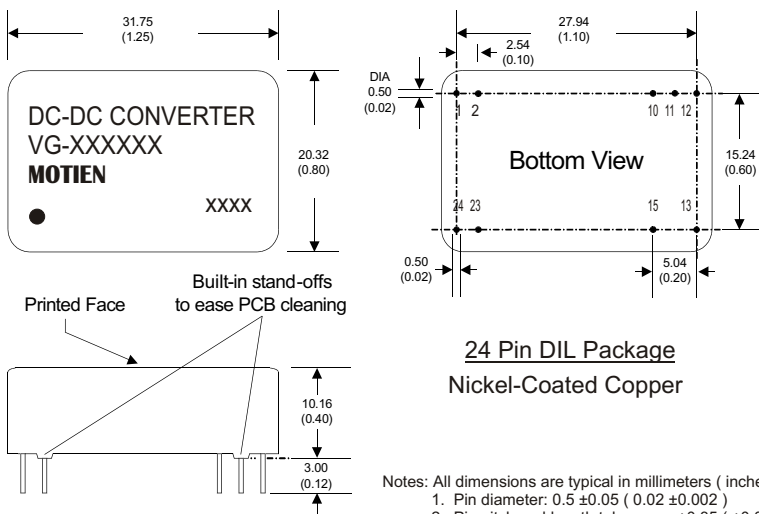

PIN CONNECTIONS		
PIN NUMBER	SINGLE	DUAL
1	+V Input	+V Input
2	+V Input	+V Input
10	N.C.	Common
11	N.C.	Common
12	-V Output	N.C.
13	+V Output	-V Output
15	N.C.	+V Output
23	-V Input	-V Input
24	-V Input	-V Input

(The Pin Connection of high isolation one is the same with normal one.)

MECHANICAL SPECIFICATIONS

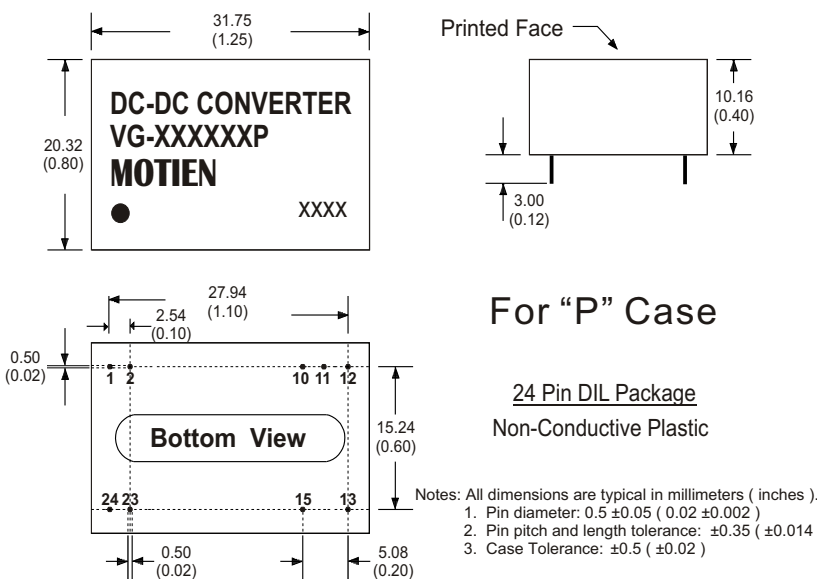

PIN CONNECTIONS		
PIN NUMBER	SINGLE	DUAL
1	+V Input	+V Input
2	+V Input	+V Input
10	N.C.	Common
11	N.C.	Common
12	-V Output	N.C.
13	+V Output	-V Output
15	N.C.	+V Output
23	-V Input	-V Input
24	-V Input	-V Input

(The Pin Connection of high isolation one is the same with normal one.)