

RBW Series



2W 4:1 Regulated Single & Dual output

Features

- 8 Pin SIL
- Wide 4:1 Input Range
- Full SMD Technology
- 1600 VDC Isolation
- Continuous Short Circuit Protection
- Efficiency up to 79%
- -40°C ~ 85°C Operation Temperature Range
- Remote on/off Control



The RBW series is a family of cost effective and high performed 2W single & dual output DC-DC converters. These converters are built in non-conductive black plastic package in a 8-pin SIL miniature compact case with high performance features wide range devices operate over 4:1 input voltage range providing stable output voltage which is much smaller than package of DIL 24- Same power rating but only 43% of the traditional volume. Devices are encapsulated using flame retardant resin. Input voltages of 12, 24, 48 with output voltage of 3.3, 5, 12, 15, ± 5 , ± 12 , ± 15 Vdc. High performance features include high efficiency operation up to 79% and output voltage accuracy of $\pm 1\%$ maximum.

All specifications typical at $T_a=25^\circ\text{C}$, nominal input voltage and full load unless otherwise specified

OUTPUT SPECIFICATIONS	
Voltage Accuracy	$\pm 1\%$
Maximun Output Current	See table
Line Regulation	$\pm 0.2\%$, max.
Load Regulation	Single (From 0% to 100% Load) $\pm 1.0\%$, max. Dual (From 10% to 100% Load) $\pm 1.0\%$, max.
Cross Regulation (Dual Output) (1)	$\pm 5\%$
Ripple & Noise (20 Mhz bandwidth)(2)	30mVpp, max.
Short Circuit Protection	Indefinite (Automatic Recovery)
Temperature Coefficient	$\pm 0.02\%/^\circ\text{C}$
Capacitive Load(3)	See table
Transient Recovery Time (4)	250us, typ.
Transient Response Deviation(4)	$\pm 3\%$, max.

INPUT SPECIFICATIONS	
Voltage Range	See table
Start up Time(Nominal V_{in} and constant resistive load)	30mS, typ.
Max. Input Current	See table
No-Load Input Current	See table
Input Filter	Capacitor
Input Reflected Ripple Current(5)	20mA pk-pk
Remote on/off	
ON:	open or high impedance
OFF:	2-4mA input current (via 1K)
Off stand by input current(Nominal V_{in})	2.5mA, max.

GENERAL SPECIFICATIONS	
Efficiency	See table, typ.
I/O Isolation Voltage (60 sec)	1600Vdc
I/O Isolation Capacity	200 pF, max.
I/O Isolation Resistance	1000M Ohm, min.
Switching Frequency	100kHz, min.
Humidity	95%relH
Reliability Calculated MTBF (MIL-HDBK-217 F)	>1.7Mhrs@25°C
Safety Standard(designed to meet)	IEC60950-1

PHYSICAL SPECIFICATIONS	
Case Material	Non conductive black plastic
Potting Material	Silicon (UL94V-0 rated)
Pin Material	C5191R-H Solder-coated
Weight	4.8g, typ.
Dimensions	0.86"x0.36"x0.44"

ENVIRONMENT SPECIFICATIONS	
Operating Temperature	-40°C ~ +85°(See Derating Curve)
	-40°C ~ +71°C(For 100% load)
Maximum Case Temperature	100°C
Storage Temperature	-40°C~125°C
Cooling	Nature Convection

ABSOLUTE MAXIMUM RATINGS(6)	
These are stress ratings. Exposure of devices to any of these conditions may adversely affect long-term reliability.	
Input Surge Voltage(100ms max)	
12 Models	25Vdc, max.
24 Models	50Vdc, max.
48 Models	100Vdc, max.
Soldering Temperature (1.5mm from case 10 sec. max.)	260°C max.

EMC SPECIFICATIONS		
Radiated Emissions	EN55022	CLASS A
Conducted Emissions (7)	EN55022	CLASS A
ESD	IEC 61000-4-2	Perf. Criteria A
RS	IEC 61000-4-3	Perf. Criteria A
EFT (8)	IEC 61000-4-4	Perf. Criteria A
Surge (8)	IEC 61000-4-5	Perf. Criteria A
CS	IEC 61000-4-6	Perf. Criteria A
PFMF	IEC 61000-4-8	Perf. Criteria A

The information and specifications contained in this data sheet are believed to be correct at time of publication. However, MOTIEN Technologies accepts no responsibility for consequences arising from printing errors or inaccuracies. Specifications are subject to change without notice. No rights under any patent accompany the sale of any such product(s) or information contained herein.

RBW - 2W 4:1 Regulated Single & Dual output

PART NUMBER STRUCTURE

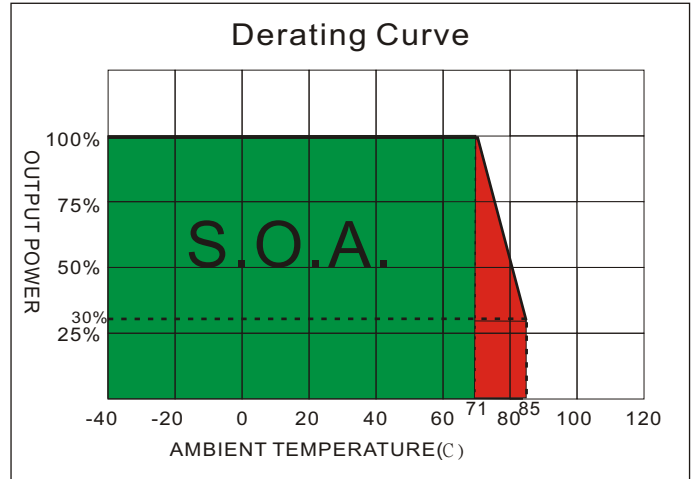
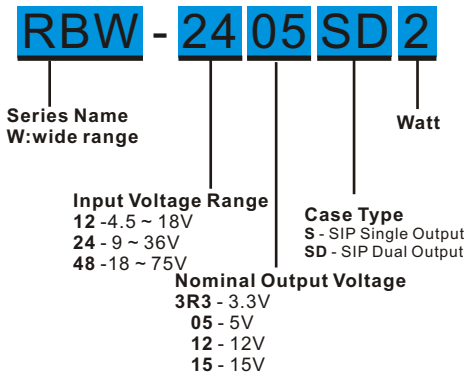

MODEL SELECTION GUIDE

MODEL NUMBER	INPUT Voltage Range (Vdc)	INPUT Current		OUTPUT Voltage (Vdc)	OUTPUT Current		EFFICIENCY @FL(%)	Capacitor Load(uF)
		No-Load (mA)	Full Load (mA)		Min. load (mA)	Full load (mA)		
RBW-123R3S2	4.5-18	40	196	3.3	0	500	70	1000uF
RBW-1205S2	4.5-18	40	225	5	0	400	74	1000uF
RBW-1212S2	4.5-18	40	213	12	0	167	78	220uF
RBW-1215S2	4.5-18	40	213	15	0	133	78	100uF
RBW-1205SD2	4.5-18	30	219	±5	0	±200	77	±470uF
RBW-1212SD2	4.5-18	30	213	±12	0	±83	78	±100uF
RBW-1215SD2	4.5-18	40	216	±15	0	±66	77	±47uF
RBW-243R3S2	9-36	25	96	3.3	0	500	71	1000uF
RBW-2405S2	9-36	20	106	5	0	400	78	1000uF
RBW-2412S2	9-36	30	105	12	0	167	79	220uF
RBW-2415S2	9-36	30	105	15	0	133	79	100uF
RBW-2405SD2	9-36	30	111	±5	0	±200	75	±470uF
RBW-2412SD2	9-36	30	108	±12	0	±83	77	±100uF
RBW-2415SD2	9-36	30	106	±15	0	±66	78	±47uF
RBW-483R3S2	18-75	10	47	3.3	0	500	72	1000uF
RBW-4805S2	18-75	15	55	5	0	400	75	1000uF
RBW-4812S2	18-75	15	55	12	0	167	75	220uF
RBW-4815S2	18-75	15	54	15	0	133	76	100uF
RBW-4805SD2	18-75	15	56	±5	0	±200	74	±470uF
RBW-4812SD2	18-75	15	56	±12	0	±83	74	±100uF
RBW-4815SD2	18-75	15	55	±15	0	±66	75	±47uF

NOTE

- One load is 25% to 100% load, the other load is 100% load, the output voltage variable rate is within ±5%.
- Measured with a 1uF ceramic capacitor.
- Test by minimal Vin and constant resistive load.
- Test by normal Vin and 100%-25% load, 25% load step change.
- Measured Input reflected ripple current with a simulated source inductance of 12uH and a source capacitor Cin(47uF, ESR<1.0Ω at 100KHz).
- Exceeding the absolute ratings of the unit could cause damage. It's not allowed for continuous operating ratings.
- Input filter components are required to help meet conducted emission class A, which application refer to the EMI Filter of design & feature configuration.
- An external filter capacitor is required if the module has to meet IEC61000-4-4 and IEC61000-4-5.
The filter capacitor Motien suggest: Nippon - chemi - con KY series, 220uF/100V.

TEST CONFIGURATIONS

Input Reflected Ripple Current Test Step

Input reflected ripple current is measured through a source inductor L_{in} (12uH) and a source capacitor C_{in} (47uF, ESR<1.0Ω at 100KHz) at nominal input and full load.

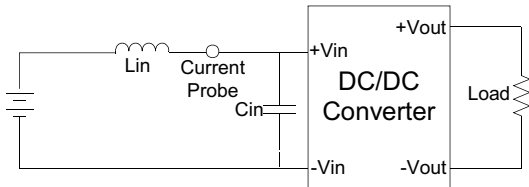

EMI Filter

Input filter components (C1, L) are used to help meet conducted emissions requirement for the module. These components should be mounted as close as possible to the module; and all leads should be minimized to decrease radiated noise.

Output Ripple & Noise Measurement Test

Use a capacitor C_{out} (1.0uF) measurement. The Scope measurement bandwidth is 0-20MHz.

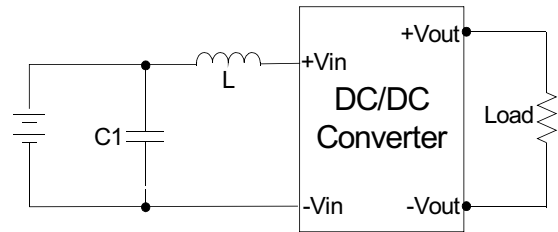
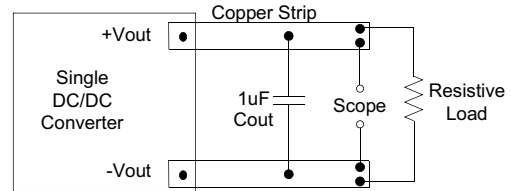

	C1	L
RBW-12XXXXXX	1210 10uF/35V	2.5uH
RBW-24XXXXXX	1210 2.2uF/100V	10uH
RBW-48XXXXXX	1210 2.2uF/100V	18uH

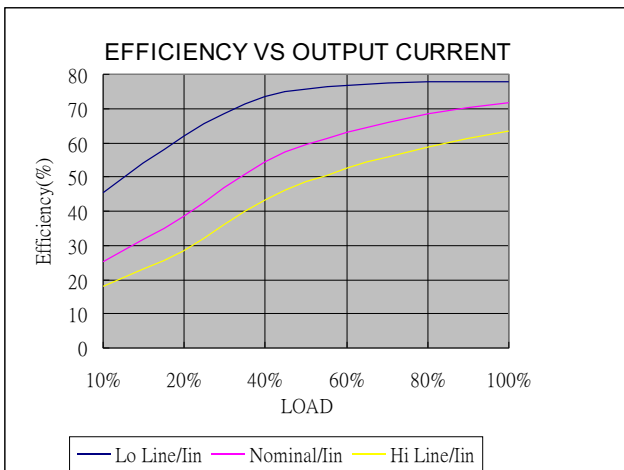

RBW-123R3S2

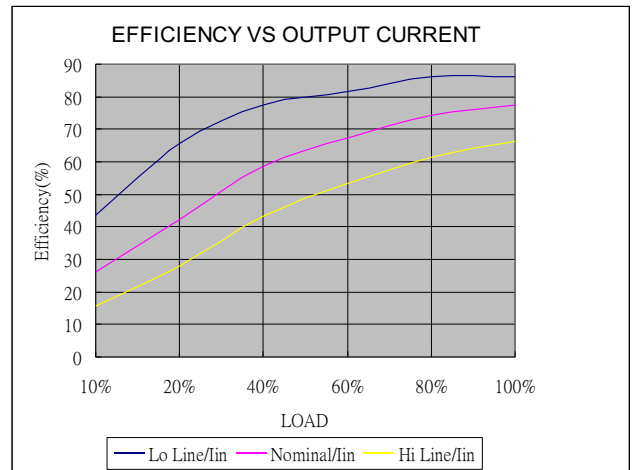

RBW-4815SD2

MECHANICAL SPECIFICATIONS

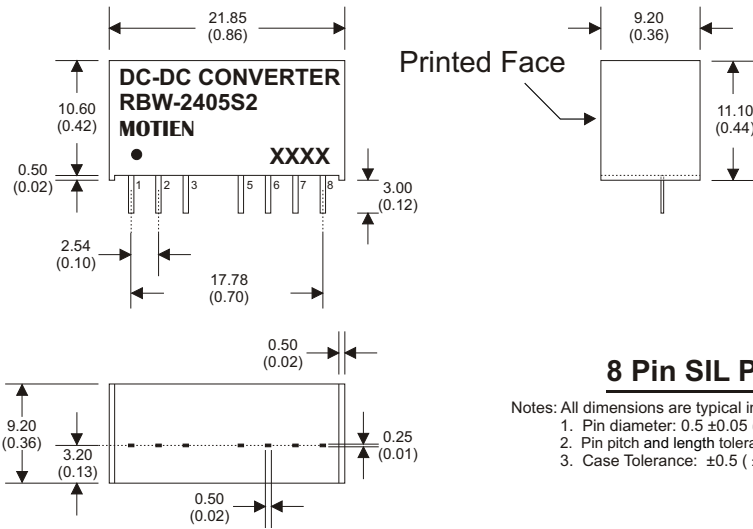

8 Pin SIL Package

- Notes: All dimensions are typical in millimeters (inches).
1. Pin diameter: 0.5 ± 0.05 (0.02 ± 0.002)
 2. Pin pitch and length tolerance: ± 0.35 (± 0.014)
 3. Case Tolerance: ± 0.5 (± 0.02)

PIN CONNECTIONS		
PIN NUMBER	SINGLE	DUAL
1	-V Input	-V Input
2	+V Input	+V Input
3	Remote On/Off	Remote On/Off
5	N.C.	N.C.
6	+V Output	+V Output
7	-V Output	Common
8	N.C.	-V Output