

MDL14 Series

High Efficiency Step Down LED Driver



Features

- RoHS-compliant 8 Pin DIL Package
- Constant Current Output (±8% Output Current Accuracy)
- LED Driver Current 300 / 350 / 500 / 600 / 700 / 1000 mA
- Power LED Driver
- Wide Input Voltage Range: 7V to 16V (20V for 0.5sec.)
- Output Power 4.2 / 4.9 / 7 / 8.4 / 9.8 / 14 W
- Driver LED Strings of up to 14V (2V to 14V)
- High Efficiency (up to 93%)
- PWM/Digital Dimming and Analog Voltage Dimming
- Open and Short LED Protection
- -40°C ~ 85°C Operation Temperature Range
- With MLCC Capacitors only



Application

- 12V Lighting Systems
- Household/Commercial lighting
- Suitable for high illumination LED
- Power limited (battery) lighting system

MDL14 Series is a high efficiency step-down converter optimized to drive high current LEDs. The control algorithm allows highly efficient and accurate LED current regulation. The device operates from an input 7Vdc to 16Vdc and provides an externally adjustable output current of up to 1000mA and output power up to 14 watts. Compact size of DIL8 allows designer to integrate this driver together with LED module. UL 94V-0 grade molded case with high grade filling material provide excellent fire proof characters.

(Typical at Ta = +25°C, nominal input voltage, rated output current unless otherwise specified.)

ELECTRICAL SPECIFICATIONS:		DIMMING CONTROL AND ON/OFF CONTROL (Leave Open if Not Used):	
Input Voltage (Vdc)	7V ~ 16V, 12Vdc Nominal	V _{ADJ} Pin Input Voltage Range	0V to 1.25V
Input Filter	Capacitor	V _{ADJ} Pin Drive Current (V _{ADJ} = 1.25V)	<1mA
Output Voltage Range (V _{in} = 16V)	2V to 14V	Analog Dimming	
Output Current Range (V _{in} - V _{out} > 2V to 3V)	See table	Adjust Output Current (V _{in} - V _{out} < 10V)	25% to 100%
Output Current Accuracy	See table	Control Voltage Range Limits	
Output Power	See table	On	0.3V < V _{ADJ} < 1.25V
Ripple and Noise, (20 MHz bandwidth)	See table	Off	V _{ADJ} < 0.15V
Maximum Efficiency at Full Load	93%	PWM Dimming	
Capacitive Load	47uF	Recommended Maximum Operation Frequency	1KHz
Operating Frequency	60 kHz ~ 400 kHz	Adjust Output Current	0% to 100%
Short Circuit Protection	Regulated at Rated Output Current	Remote ON/OFF	
Temperature Coefficient	±0.03%/°C, max.	DC/DC ON	0.3V < V _{ADJ} < 1.25V or open circuit
Thermal Impedance (Nature Convection)	+35°C/W	DC/DC OFF (Shutdown)	V _{ADJ} < 0.15V or Short circuit pin 7 and pin 8
Safety Standard : (designed to meet)	IEC / EN 60950-1	Quiescent Input Current in Shutdown Mode (V _{in} = 16V)	25µA, max.
ENVIRONMENTAL SPECIFICATIONS		EMC SPECIFICATIONS	
Operating Temperature Range	-40°C to +85°C (See Derating Curve)	EMI Radiated & Conducted Emissions	EN 55015 (CISPR22)
Storage Temperature Range	-40°C to +125°C	EMS Immunity EN61547	
Humidity	95% rel H	IEC 61000-4-2	Perf. Criteria A
Maximum Case Temperature	+105°C	IEC 61000-4-3	Perf. Criteria A
Cooling	Nature Convection	IEC 61000-4-4	Perf. Criteria A
Reliability Calculated MTBF (MIL-HDBK-217 F)	>3.3 Mhrs	IEC 61000-4-6	Perf. Criteria A
Soldering Temperature (1.5mm from case 10 sec. max.)	+260°C, max.	IEC 61000-4-8	Perf. Criteria A
PHYSICAL SPECIFICATIONS			
Case Material	Non-Conductive Black Plastic (UL94V-0 rated)		
Potting Material	Silicon (UL94V-0 rated)		
Pin Material	Ø0.5mm Brass Solder-coated		
Weight	1.8g		
Dimensions	0.80"x0.40"x0.27"		
NOTE			
1. Reversed power source damages the circuit, No connection is allowed between input ground and output.			
2. DO NOT operate the driver over output power.			
3. Leave pin V _{ADJ} open if not in use, ground pin to shut down the converter. Connecting V _{ADJ} to V _{in} damages the circuit.			
4. Maximum output open voltage is equal to input voltage.			
5. Input filter components (C1, C2, L, C3) are used to help meet conducted emissions requirement for the module.			
6. For the compliance with IEC61000-4-5, a TVS is thus recommended to be installed in front of the input filter, the reference model: 3.0SMCJ15A or SMCJ16A (TVS Max Clamping Voltage @ Max Peak Pulse Current VC (V) ≤ 20V)			

The information and specifications contained in this data sheet are believed to be correct at time of publication. However, MOTIEN Technologies accepts no responsibility for consequences arising from printing errors or inaccuracies. Specifications are subject to change without notice. No rights under any patent accompany the sale of any such product(s) or information contained herein.

PART NUMBER STRUCTURE

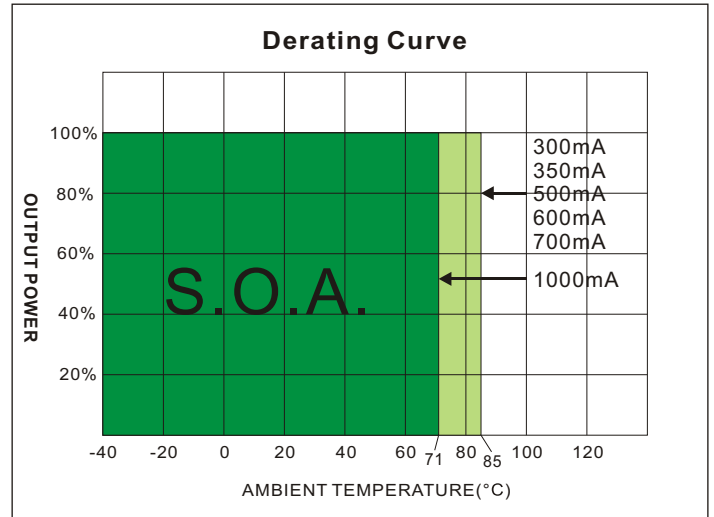
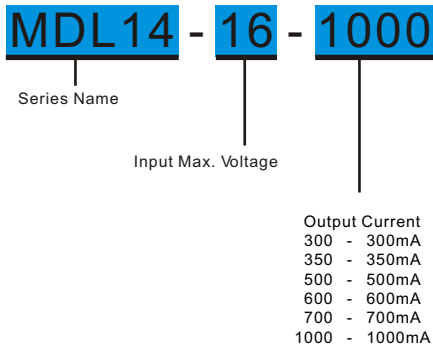

MODEL SELECTION GUIDE

MODEL NUMBER	INPUT	OUTPUT		OUTPUT Current	OUTPUT	EFFICIENCY	Ripple and Noise	Capacitor
	Voltage Range (Vdc)	Voltage Range (Vdc)	Current (mA)	Accuracy (%)	Power (W) Max.			
MDL14-16-300	7-16	2 ~ 14	300	±5	4.2	93	120	47
MDL14-16-350	7-16	2 ~ 14	350	±6	4.9	93	150	47
MDL14-16-500	7-16	2 ~ 14	500	±7	7.0	93	200	47
MDL14-16-600	7-16	2 ~ 14	600	±7	8.4	93	200	47
MDL14-16-700	7-16	2 ~ 14	700	±7	9.8	93	250	47
MDL14-16-1000	7-16	2 ~ 14	1000	±8	14.0	93	250	47

EMC COUNTERMEASURES

EMC Countermeasures Suggestion

Input filter components (C1, C2, L, C3) are used to help meet conducted emissions requirement for the module.

These components should be mounted as close as possible to the module; and all leads should be minimized to decrease radiated noise.

For the compliance with IEC61000-4-5, a TVS is thus recommended to be installed in front of the input filter.

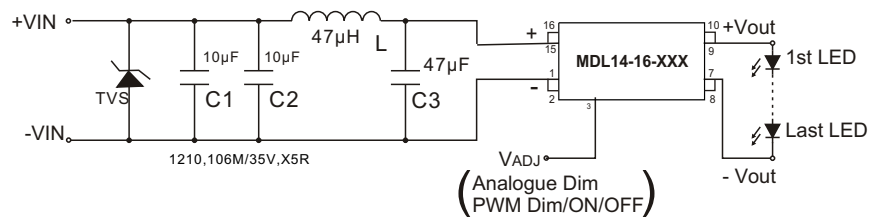

MECHANICAL DIMENSION

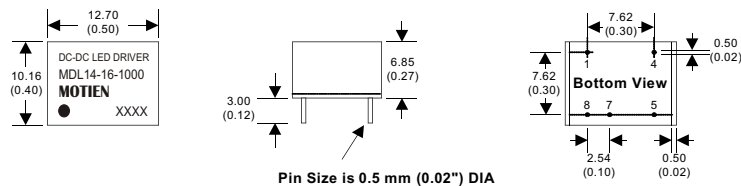

8 Pin DIL Package

- Notes : All dimensions are typical in millimeters (inches).
1. Pin diameter: 0.5±0.05 (0.02±0.002)
 2. Pin pitch and length tolerance: ±0.35 (±0.014)
 3. Case Tolerance: ±0.5 (±0.02)

Pin #	CONNECTIONS	
1	+V Input	+DC Supply
4	+V Output	LED Anode Connection
5	- V Output	LED Cathode Connection
7	VADJ	Dimming Control
8	- V Input	- DC Supply

No connection is allowed between input and output

TYPICAL OPERATING CONDITIONS

MDL14-16-300

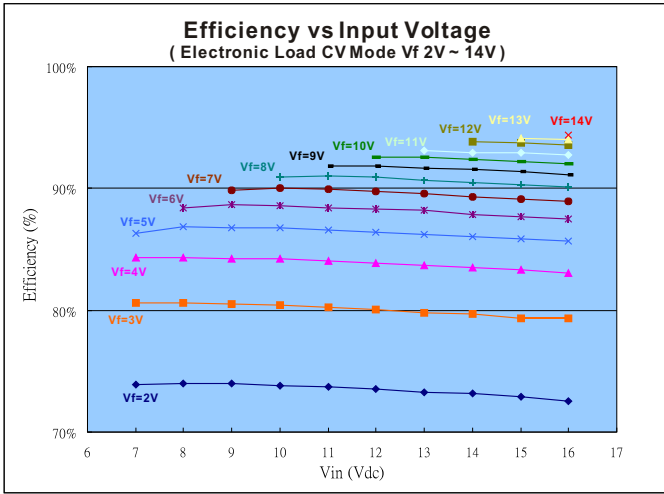

MDL14-16-600

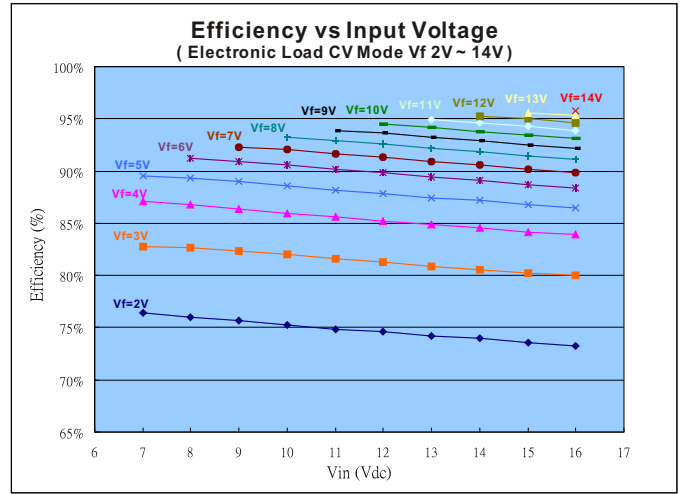

MDL14-16-350

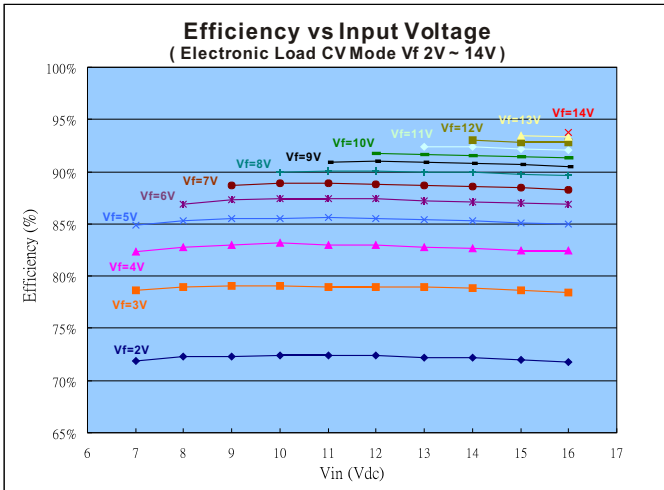

MDL14-16-700

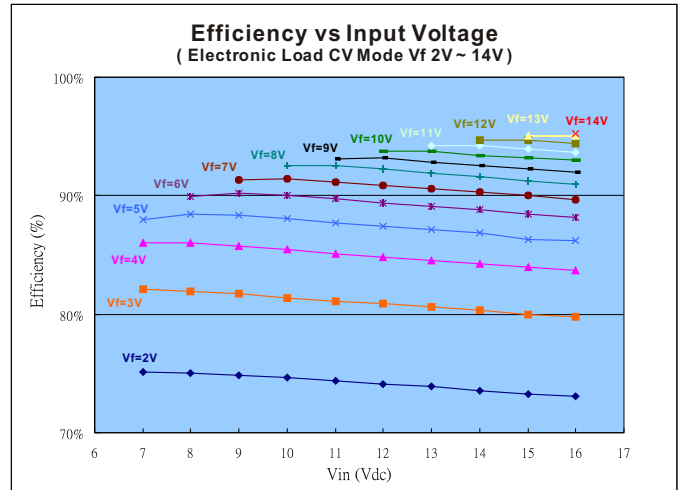

MDL14-16-500

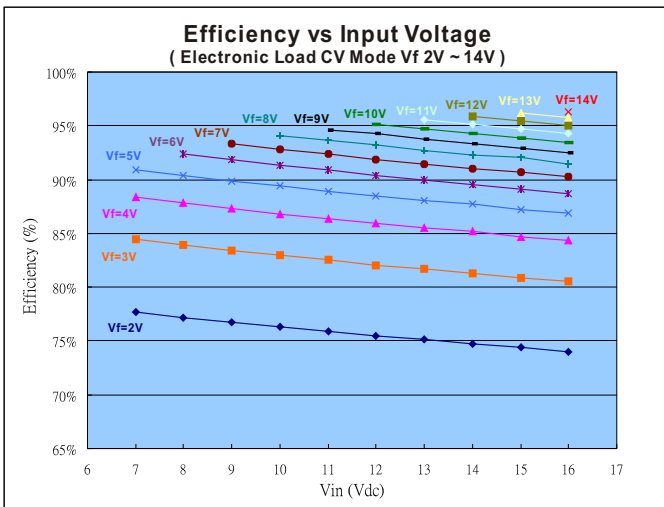

MDL14-16-1000

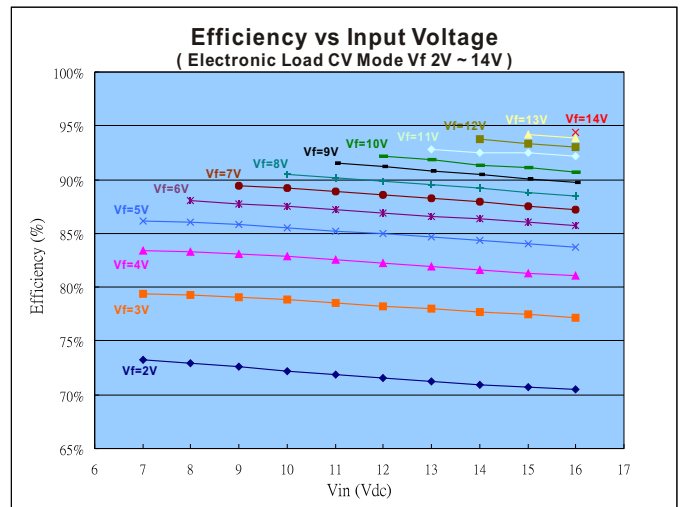

TYPICAL APPLICATION

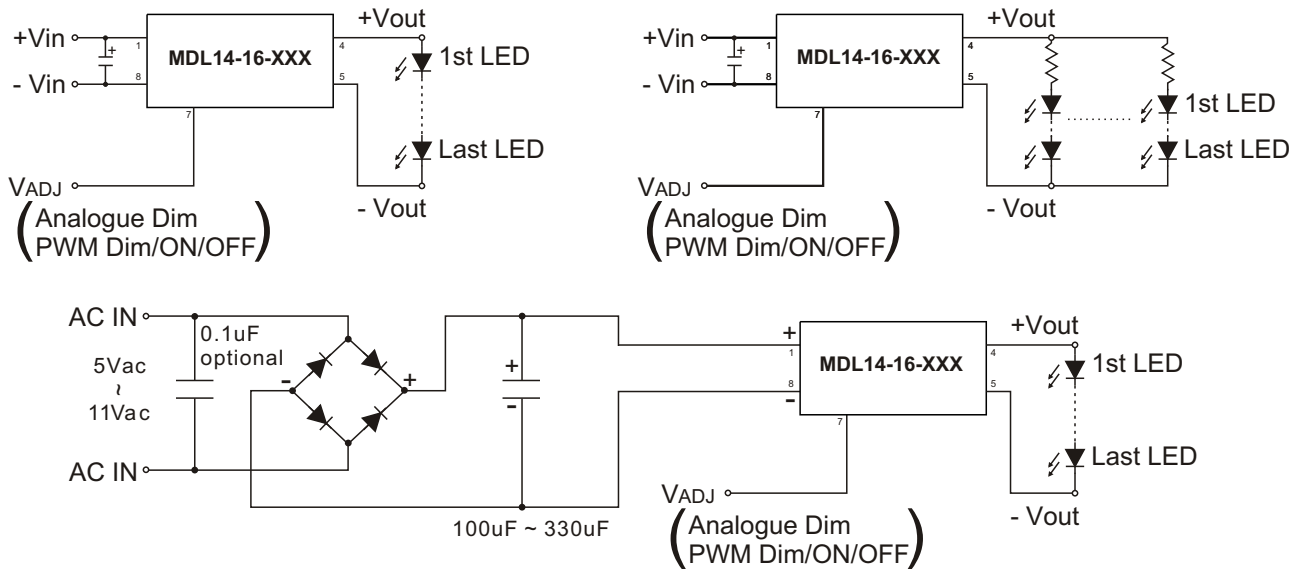

Output Current Adjustment By External DC Control Voltage

The nominal output current is then given by:

$$I_{outnom} \approx I_{out} \times \frac{V_{ADJ}}{1.25}$$

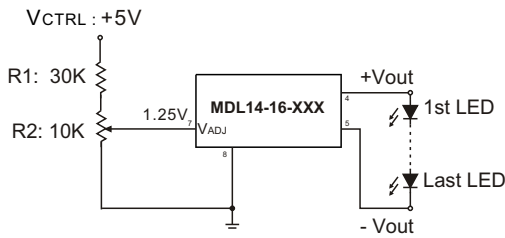
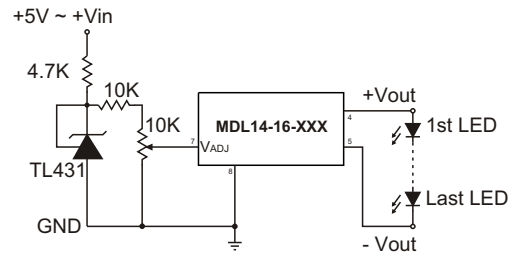
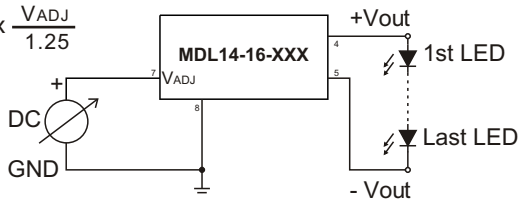

$$V_{ADJ} = \frac{R2}{R1 + R2} \times V_{CTRL}$$

Resistor dimming

By connecting a variable resistor between ADJ and GND, simple dimming can be achieved. Capacitor CADJ is optional for better AC mains interference and HF noise rejection. Recommend value of CADJ is 0.22uF.

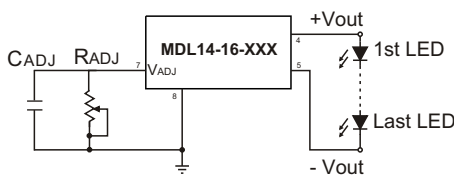

The current output I_{outnom} can be determined using the equation:

$$I_{outnom} = \frac{I_{out} \times R_{ADJ}}{(R_{ADJ} + 200K)}$$

If the value of RADJ is 0 to 2M ohm, the maximum adjust range of output current is 25% to 90%. (For Vin-Vout < 10Vdc)

TYPICAL APPLICATION

Output Current Adjustment By PWM Control

Directly driving ADJ input

A Pulse Width Modulated (PWM) signal with duty cycle, D_{PWM} , can be applied to the ADJ pin, as shown below

$$I_{out_{nom}} \approx I_{out} \times D_{PWM} \quad [\text{If PWM frequency} < 200\text{Hz, for } 0.1 < D_{PWM} < 1]$$

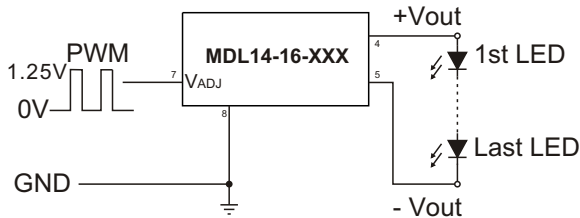

Driving the ADJ input via open collector transistor

The diode and resistor suppress possible high amplitude negative spikes on the ADJ input resulting from the drain-source capacitance of the transistor. Negative spikes at the input to the device should be avoided as they may cause errors in output current, or erratic device operation.

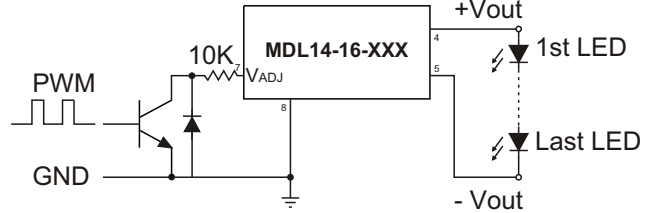

Driving the ADJ input from a microcontroller

Another possibility is to drive the device from the open drain output of a microcontroller. The diagram below shows one method of doing this:

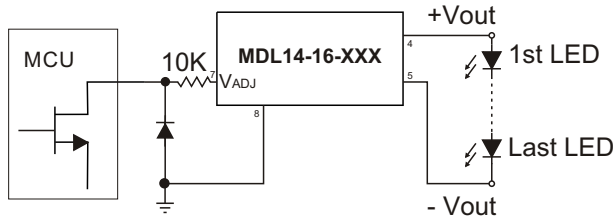

The diode and resistor suppress possible high amplitude negative spikes on the ADJ input resulting from the drain-source capacitance of the FET. Negative spikes at the input to the device should be avoided as they may cause errors in output current, or erratic device operation.

Output Current Adjustment By PWM Control (Dimming)

To avoid visible flicker the PWM signal must be greater than 100Hz.

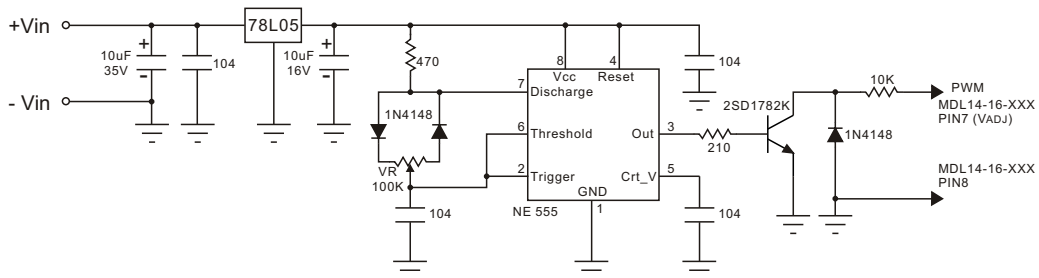

Output Current Adjustment By PWM Control (Flash)

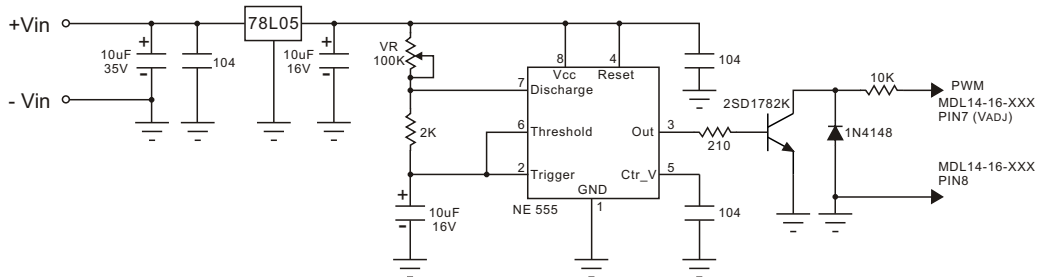

The information and specifications contained in this data sheet are believed to be correct at time of publication. However, MOTIEN Technologies accepts no responsibility for consequences arising from printing errors or inaccuracies. Specifications are subject to change without notice. No rights under any patent accompany the sale of any such product(s) or information contained herein.