

V7 - 10W Series



10W 2:1 Regulated Single & Dual output

Features

- Wide 2:1 Input Range
- Full SMD Technology
- 1500~3500 VDC Isolation
- Continuous Short Circuit Protection
- Efficiency up to 86%
- -40 ~ 85°C Operation Temperature Range
- EMI Complies With EN55022 Class A

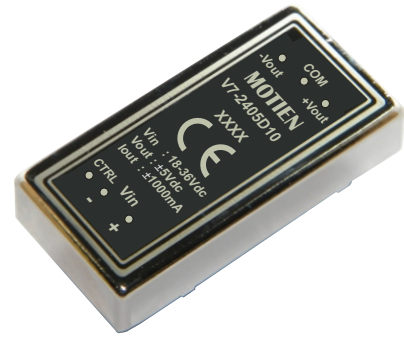

The V7 series is a family of cost effective 10W single & dual output DC-DC converters. These converters are made with nickle-coated brass case in a 2"x1" with high performance features such as 1500 VDC input/output isolation voltage, continuous short circuit protection with automatic restart and tight line / load regulation. Devices are encapsulated by using flame retardant resin. Input voltages of 12,24 and 48 with output voltage of 3.3,5,7.2,9,12,15,18,24,±3.3,±5,±7.2,±9,±12,±15,±18,±24 Vdc. High performance features include high efficiency operation up to 86% and output voltage accuracy of ±1% maximum.

All specifications typical at Ta=25°C, nominal input voltage and full load unless otherwise specified

OUTPUT SPECIFICATIONS	
Voltage accuracy	±1%
Line regulation	±0.5%
Load regulation(0% to 100% Load)	(Single Output) ±0.5% (Dual Output) ±1.0%
Ripple & noise (20 MHz bandwidth)(1)	100mV pk-pk
Over-current protection	140% of max. Iout
Short circuit protection	Indefinite(Automatic Recovery)
Temperature coefficient	±0.02%/°C
Capacitor load(2)	See table
Transient Recovery Time(3)	250us, typ.
Transient Response Deviation(3)	±3%, max.

INPUT SPECIFICATIONS	
Voltage Range	See table
Start up Time(Nominal Vin and constant resistive load)	20mS, typ.
Max. Input Current	See table
No-Load Input Current	See table
Input Filter	Pi Type
Input Reflected Ripple Current(4)	35mA pk-pk

GENERAL SPECIFICATIONS	
Efficiency	See table
I/O Isolation Voltage(60 sec)	1500~3500Vdc
Input/Output Case/Input & Output	1000Vdc
I/O Isolation Capacitance	500 pF Typ.
I/O Isolation Resistance	1000M Ohm
Switching Frequency	Typical 200kHz
Humidity	95% rel H
Reliability Calculated MTBF(MIL-HDBK-217 F)	>1.121 Mhrs
Safety Standard : (designed to meet)	IEC 60950-1

EMC SPECIFICATIONS		
Radiated Emissions	EN55022	CLASS A
Conducted Emissions(5)	EN55022	CLASS A
ESD	IEC61000-4-2	Perf. Criteria A
RS	IEC61000-4-3	Perf. Criteria A
EFT	IEC61000-4-4	Perf. Criteria A
Surge (6)	IEC61000-4-5	Perf. Criteria A
CS	IEC61000-4-6	Perf. Criteria A
PFMF	IEC61000-4-8	Perf. Criteria A

PHYSICAL SPECIFICATIONS	
Case Material	Nickel-coated Brass
Pin Material	Φ1.0mm Brass Solder-coated
Potting Material	Epoxy (UL94V-0 rated)
Weight	30.0g
Dimensions	2.00"x1.00"x0.40"

ENVIRONMENT SPECIFICATIONS	
Operating Temperature	-40°C~85°C(See Derating Curve)
Maximum Case Temperature	100°C
Storage Temperature	-40°C~125°C
Cooling	Nature Convection

ABSOLUTE MAXIMUM RATINGS(7)	
These are stress ratings. Exposure of devices to any of these conditions may adversely affect long-term reliability.	
Input Surge Voltage(100mS)	25 Vdc, max.
12 Models	50 Vdc, max.
24 Models	100 Vdc, max.
48 Models	
Soldering Temperature (1.5mm from case 10 sec.max.)	260°C

The information and specifications contained in this data sheet are believed to be correct at time of publication. However, MOTIEN Technologies accepts no responsibility for consequences arising from printing errors or inaccuracies. Specifications are subject to change without notice. No rights under any patent accompany the sale of any such product(s) or information contained herein.

V7 - 10W 2:1 Regulated Single & Dual output

PART NUMBER STRUCTURE

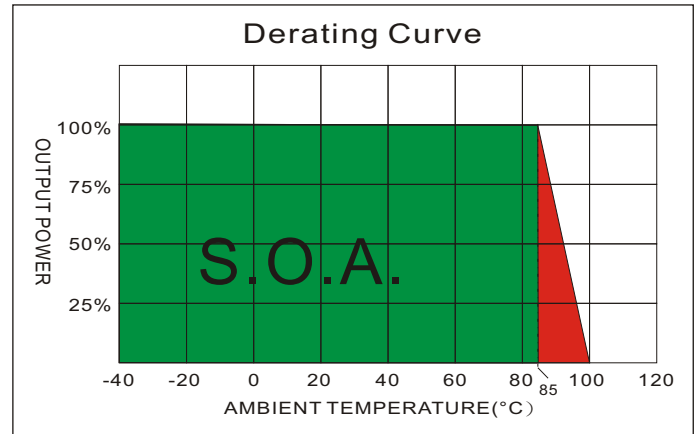
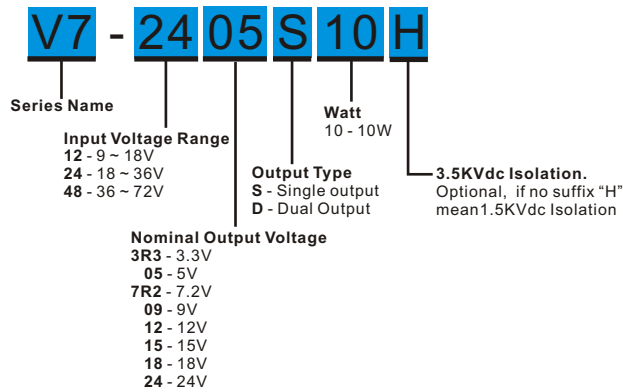

MODEL SELECTION GUIDE

MODEL NUMBER	INPUT Voltage Range (Vdc)	INPUT Current		OUTPUT Voltage (Vdc)	OUTPUT Current		EFFICIENCY @FL(%)	Capacitor Load(uF)
		No Load (mA)	Full Load (mA)		Min Load (mA)	Full Load (mA)		
V7-123R3S10	9-18	30	705	3.3	0	2000	78	2200
V7-1205S10	9-18	30	1016	5	0	2000	82	2200
V7-127R2S10	9-18	30	1004	7.2	0	1388	83	1000
V7-1209S10	9-18	30	1004	9	0	1111	83	1000
V7-1212S10	9-18	30	992	12	0	833	84	680
V7-1215S10	9-18	30	992	15	0	666	84	470
V7-1218S10	9-18	30	980	18	0	555	85	470
V7-1224S10	9-18	30	980	24	0	416	85	330
V7-123R3D10	9-18	30	1068	±3.3	0	±1000	78	±1000
V7-1205D10	9-18	30	1016	±5	0	±1000	82	±1000
V7-127R2D10	9-18	30	1004	±7.2	0	±694	83	±680
V7-1209D10	9-18	30	992	±9	0	±555	84	±470
V7-1212D10	9-18	30	992	±12	0	±416	84	±470
V7-1215D10	9-18	30	980	±15	0	±333	85	±330
V7-1218D10	9-18	30	980	±18	0	±277	85	±220
V7-1224D10	9-18	30	980	±24	0	±208	85	±220
V7-243R3S10	18-36	25	352	3.3	0	2000	78	2200
V7-2405S10	18-36	25	508	5	0	2000	82	2200
V7-247R2S10	18-36	25	502	7.2	0	1388	83	1000
V7-2409S10	18-36	25	496	9	0	1111	84	1000
V7-2412S10	18-36	25	496	12	0	833	84	680
V7-2415S10	18-36	25	490	15	0	666	85	470
V7-2418S10	18-36	25	490	18	0	555	85	470
V7-2424S10	18-36	25	484	24	0	416	86	330
V7-243R3D10	18-36	25	352	±3.3	0	±1000	78	±1000
V7-2405D10	18-36	25	508	±5	0	±1000	82	±1000
V7-247R2D10	18-36	25	502	±7.2	0	±694	83	±680
V7-2409D10	18-36	25	502	±9	0	±555	83	±470
V7-2412D10	18-36	25	496	±12	0	±416	84	±470
V7-2415D10	18-36	25	496	±15	0	±333	84	±330
V7-2418D10	18-36	25	490	±18	0	±277	85	±220
V7-2424D10	18-36	25	490	±24	0	±208	85	±220

The models listed above is just for standard type. If you need the special specification product, please contact our service member by telephone presented in shortform cover or e-mail to : sales@motien.com.tw

V7 - 10W 2:1 Regulated Single & Dual output

MODEL NUMBER	INPUT Voltage Range (Vdc)	INPUT Current		OUTPUT Voltage (Vdc)	OUTPUT Current		EFFICIENCY @FL(%)	Capacitor Load(uF)
		No Load (mA)	Full Load (mA)		Min Load (mA)	Full Load (mA)		
V7-483R3S10	36-72	20	176	3.3	0	2000	78	2200
V7-4805S10	36-72	20	251	5	0	2000	83	2200
V7-487R2S10	36-72	20	251	7.2	0	1388	83	1000
V7-4809S10	36-72	20	248	9	0	1111	84	1000
V7-4812S10	36-72	20	248	12	0	833	84	680
V7-4815S10	36-72	20	248	15	0	666	84	470
V7-4818S10	36-72	20	245	18	0	555	85	470
V7-4824S10	36-72	20	245	24	0	416	86	330
V7-483R3D10	36-72	20	176	±3.3	0	±1000	78	±1000
V7-4805D10	36-72	20	254	±5	0	±1000	82	±1000
V7-487R2D10	36-72	20	248	±7.2	0	±694	84	±680
V7-4809D10	36-72	20	248	±9	0	±555	84	±470
V7-4812D10	36-72	20	245	±12	0	±416	85	±470
V7-4815D10	36-72	20	245	±15	0	±333	85	±330
V7-4818D10	36-72	20	242	±18	0	±277	86	±220
V7-4824D10	36-72	20	242	±24	0	±208	86	±220

Suffix "H" means 3.5KVdc isolation

NOTE

1. Measured with 20MHz bandwidth and 1.0uF ceramic capacitor.
2. Tested by minimal Vin and constant resistive load.
3. Tested by normal Vin and 25% load step change (75%-50%-25% of Io).
4. Measured input reflected ripple current with a simulated source inductance of 12uH.
5. Input filter components (C1,L,C2,C3) are used to help meet conducted emissions requirement for the module, which application refer to the EMI Filter of design & feature configuration..
These components should be mounted as close as possible to the module; and all leads should be minimized to decrease radiated Noise.
6. An external filter capacitor is required if the module has to meet IEC61000-4-5.
The filter capacitor Motien suggest: Nippon chemi-con KY series, 220uF/100V.
7. Exceeding the absolute ratings of the unit could cause damage. It is not allowed for continuous operating.
8. Operation under no-load conditions will not damage these devices, however they may not meet all listed specifications.

TEST CONFIGURATIONS

Input Reflected Ripple Current Test Step

Input reflected ripple current is measured through a source inductor L_{in} (12 μ H) and a source capacitor C_{in} (47 μ F, ESR<1.0 Ω at 100KHz) at nominal input and full load.

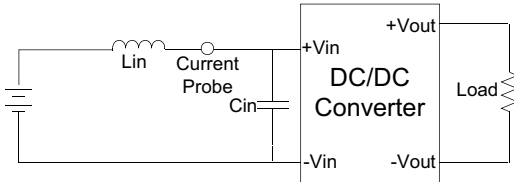

EMI Filter

Input filter components (C_1, L, C_2, C_3) are used to help meet conducted emissions requirement for the module. These components should be mounted as close as possible to the module; and all leads should be minimized to decrease radiated noise.

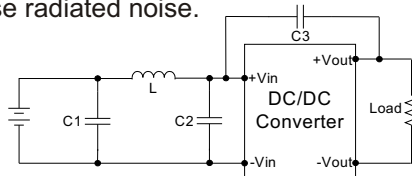

	C1	L	C2	C3
V7-12XXXXXX	330 μ F/100V	12 μ H	100 μ F/100V	1808, 102K/3KV
V7-24XXXXXX	330 μ F/100V	12 μ H	100 μ F/100V	1808, 102K/3KV
V7-48XXXXXX	330 μ F/100V	12 μ H	100 μ F/100V	1808, 102K/3KV

Output Ripple & Noise Measurement Test

Use a capacitor C_{out} (1.0 μ F) measurement. The Scope measurement bandwidth is 0-20MHz.

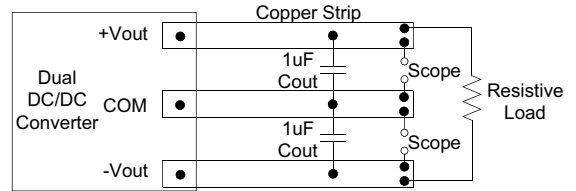

ELECTRICAL CHARACTERISTIC CURVES

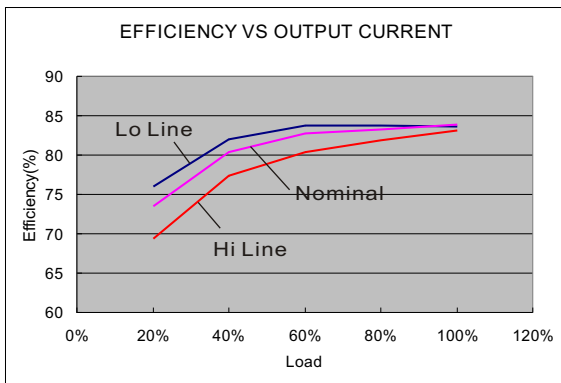

12 Models

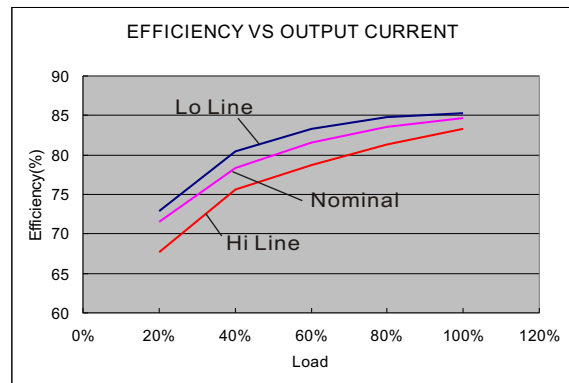

24 Models

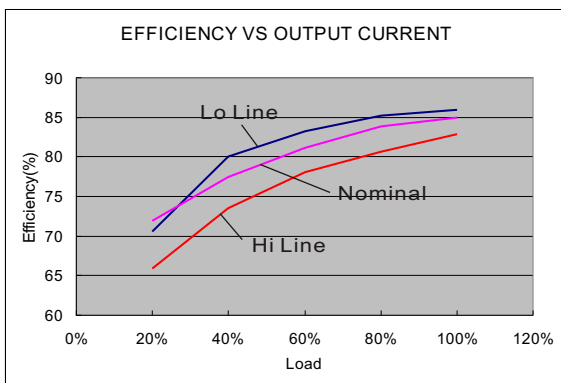

48 Models

The models listed above is just for standard type. If you need the special specification product, please contact our service member by telephone presented in shortform cover or e-mail to : sales@motien.com.tw

V7 - 10W 2:1 Regulated Single & Dual output

MECHANICAL SPECIFICATIONS

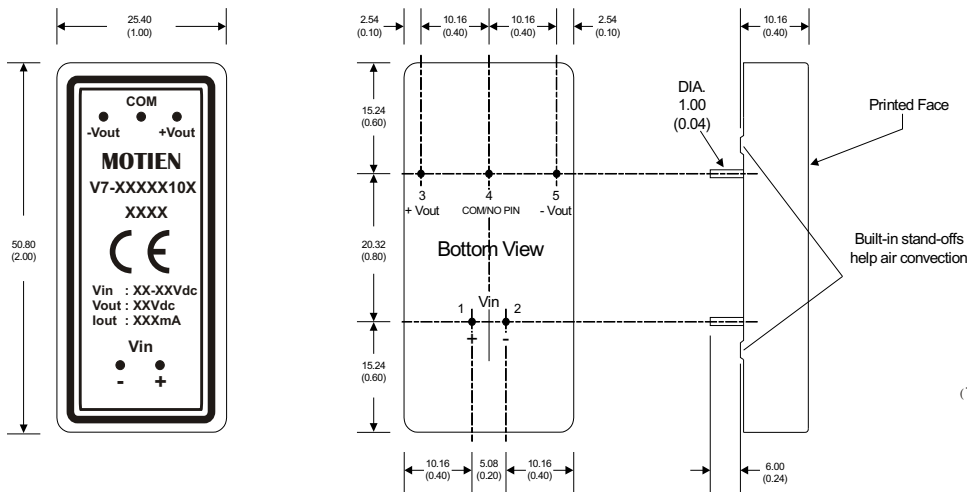

PIN CONNECTIONS		
PIN NUMBER	SINGLE	DUAL
1	+V Input	+V Input
2	-V Input	-V Input
3	+V Output	+V Output
4	N.P.	Common
5	-V Output	-V Output

(The Pin Connection of high isolation one is the same with normal one.)

- All dimensions are typical in millimeters (inches).
1. Pin diameter: 1.0 ± 0.05 (0.04 ± 0.002)
 2. Pin pitch and length tolerance: ± 0.35 (± 0.014)
 3. Case Tolerance: ± 0.5 (± 0.02)