

VV Series

12W 4:1 Regulated Single & Dual output



Features

- Wide 4:1 Input Range
- Full SMD Technology
- 1600 VDC Isolation
- Efficiency up to 90%
- -40 ~ 85 °C Operation Temperature Range
- No Minimum Load Required
- Continuous Short Circuit Protection
- Over Voltage Protection
- Over Load Protection
- Low no load Input Current
- Soft Start
- High Power Density: 12W in DIL-24 Package
- Remote On/Off



The VV series are high performance 12W single & dual output DC-DC converters. These converters are consisted with nickle-coated copper 24-pin DIL package with high performance features such as synchronous rectification, high efficiency and tight line / load regulation. Devices are encapsulated using flame retardant resin. Input voltages of 24 and 48 with output voltage of 3.3, 5.1, 12, 15, ± 5 , ± 12 , ± 15 Vdc. Features include high efficiency operation up to 90% .

ALL SPECIFICATIONS ARE TYPICAL AT 25°C, NOMINAL INPUT AND FULL LOAD UNLESS OTHERWISE NOTED.

OUTPUT SPECIFICATIONS	
Output Voltage Accuracy	$\pm 1.2\%$
Maximum Output Current	See table
Line Regulation	$\pm 0.2\%$, max.
Load Regulation (0% Load to Full Load) Single	$\pm 0.5\%$, max.
Load Regulation (0% Load to Full Load) Dual	$\pm 1.0\%$, max.
Cross Regulation (Dual Output) (1)	$\pm 5\%$
Ripple&Noise (2)	85mVpk-pk, max.
	3.3V output 3.9V
	5.1V output 6.2V
Over Voltage Protection	12V output 15V
(Zener diode clamp)	15V output 18V
	± 5 V output ± 6.2 V
	± 12 V output ± 15 V
	± 15 V output ± 18 V
Over Load Protection	170% of FL, typ.
Short Circuit Protection	Indefinite(hiccup) (Automatic Recovery)
Temperature Coefficient	$\pm 0.02\%/^{\circ}\text{C}$
Capacitive Load (3)	See table
Transient Recovery Time (4)	250us, typ.
Transient Response Deviation(4)	$\pm 3\%$, max.

INPUT SPECIFICATIONS	
Input Voltage Range	See table
Start up Time	20mS, typ.
(Nominal Vin and constant resistive load)	
Input Filter	Pi Type
Input Current(No-Load)	See table, max.
Input Current(Full-Load)	See table, typ.
Input Reflected Ripple Current	20mApk-pk
Remote On/Off (CTRL)	
	ON: 3.0 ... 12Vdc or open circuit
	OFF: 0 ... 1.2Vdc or Short circuit pin1 and pin 2/3
	OFF idle current: 5.0 mA typ.

ENVIRONMENTAL SPECIFICATIONS	
Operating Ambient Temperature	-40°C ~ +85°C(See Derating Curve)
	-40°C ~ +60°C(For 100% load)
Maximum Case Temperature	105°C
Storage Temperature	-55°C ~ +125°C
Cooling	Nature Convection

GENERAL SPECIFICATIONS	
Efficiency	See table, min.
I/O Isolation Voltage(60 sec)	
Input/Output	1600Vdc
Case/Input & Output	1600Vdc
Isolation Resistance	1000 M Ω , min.
Isolation Capacitance	1500 pF, max.
Switching frequency	270kHz, typ.
Humidity	95% rel H
Reliability Calculated MTBF(MIL-HDBK-217 F)	>1 Mhrs
Safety Standard : (designed to meet)	IEC 60950-1

EMC CHARACTERISTICS		
Radiated Emissions	EN55022	CLASSA
Conducted Emissions(5)	EN55022	CLASSA
ESD	IEC61000-4-2	Perf. Criteria B
RS	IEC61000-4-3	Perf. Criteria A
EFT (6)	IEC61000-4-4	Perf. Criteria A
Surge (6)	IEC61000-4-5	Perf. Criteria A
CS (6)	IEC61000-4-6	Perf. Criteria A
PFMF	IEC61000-4-8	Perf. Criteria A

PHYSICAL SPECIFICATIONS	
Case Material	Copper with nickel plated
Base Material	Non-conductive black plastic (UL94V-0 rated)
Pin Material	$\Phi 0.5$ mm Brass Solder-coated
Potting Material	Epoxy (UL94V-0 rated)
Weight	18.0g
Dimensions	1.25"x0.8"x0.40"

ABSOLUTE SPECIFICATIONS (7)		
These are stress ratings. Exposure of devices to any of these conditions may adversely affect long-term reliability.		
Input Surge Voltage(1000mS)	24 Models	50Vdc, max.
	48 Models	100Vdc, max.
Soldering Temperature		260°C, max.
(1.5mm from case 10 sec. max.)		

The information and specifications contained in this data sheet are believed to be correct at time of publication. However, MOTIEN Technologies accepts no responsibility for consequences arising from printing errors or inaccuracies. Specifications are subject to change without notice. No rights under any patent accompany the sale of any such product(s) or information contained herein.

VV - 12W 4:1 Regulated Single & Dual output

PART NUMBER STRUCTURE

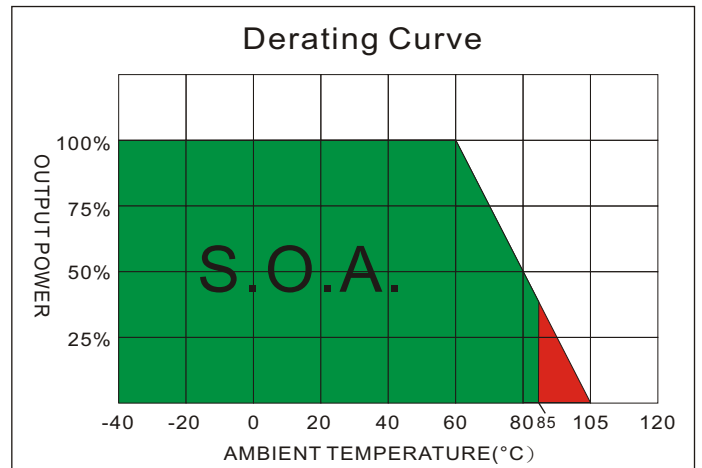
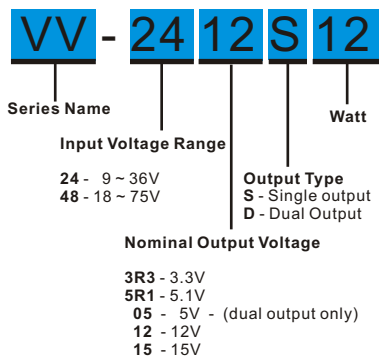

MODEL SELECTION GUIDE

MODEL NUMBER	INPUT Voltage Range (Vdc)	INPUT Current		OUTPUT Voltage (Vdc)	OUTPUT Current		EFFICIENCY @FL(%)	Capacitor Load(uF)
		No-Load (mA)	Full Load (mA)		Min. load (mA)	Full load (mA)		
VV-243R3S12	9-36	15	573	3.3	0	3500	87	2000
VV-245R1S12	9-36	15	581	5.1	0	2400	89	2000
VV-2412S12	9-36	15	574	12	0	1000	90	430
VV-2415S12	9-36	15	574	15	0	800	90	300
VV-2405D12	9-36	15	595	±5	0	±1200	87	±1250
VV-2412D12	9-36	15	574	±12	0	±500	90	±200
VV-2415D12	9-36	15	574	±15	0	±400	90	±120
VV-483R3S12	18-75	15	286	3.3	0	3500	87	2000
VV-485R1S12	18-75	15	290	5.1	0	2400	89	2000
VV-4812S12	18-75	15	287	12	0	1000	90	430
VV-4815S12	18-75	15	287	15	0	800	90	300
VV-4805D12	18-75	15	297	±5	0	±1200	87	±1250
VV-4812D12	18-75	15	287	±12	0	±500	90	±200
VV-4815D12	18-75	15	287	±15	0	±400	90	±120

NOTE

1. One load is 25% to 100% load, the other load is 100% load, the output voltage variable rate is within ±5%.
2. Measured with 20MHz bandwidth and 1.0uF ceramic capacitor.
3. Tested by minimal Vin and constant resistive load.
4. Tested by normal Vin and 25% load step change (75%-50%-25% of Io).
5. Input filter components (C1, L, C2) are used to help meet conducted emissions requirement for the module. These components should be mounted as close as possible to the module; and all leads should be minimized to decrease radiated noise.
6. An external filter capacitor is required if the module has to meet IEC61000-4-4 and IEC61000-4-5 and IEC61000-4-6 . The filter capacitor Motien suggest: Nippon - chemi - con KY series, 330uF/100V.
7. Exceeding the absolute ratings of the unit could cause damage. It is not allowed for continuous operating.

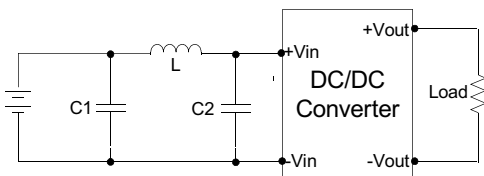

	C1	L	C2
VV-24XXXXX	2.2uF, 100V	12uH	2.2uF, 100V
VV-48XXXXX	2.2uF, 100V	12uH	2.2uF, 100V

TEST CONFIGURATIONS

Input Reflected Ripple Current Test Step

Input reflected ripple current is measured through a source inductor L_{in} (12 μ H) and a source capacitor C_{in} (47 μ F, ESR<1.0 Ω at 100KHz) at nominal input and full load.

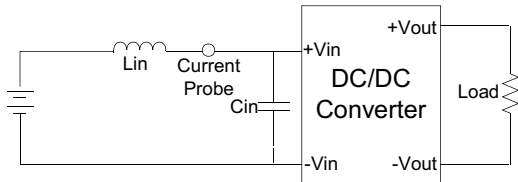

Output Ripple & Noise Measurement Test

Use a capacitor C_{out} (1.0 μ F) measurement. The Scope measurement bandwidth is 0-20MHz.

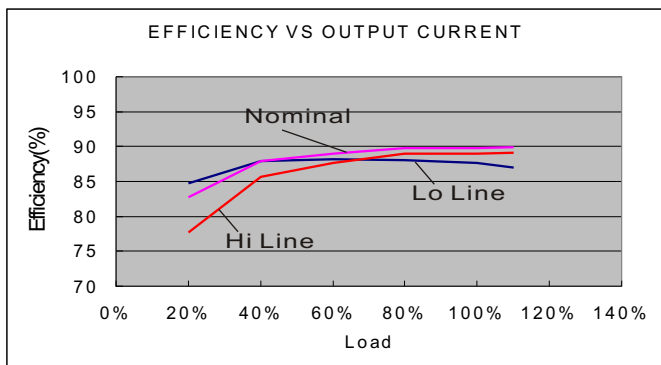
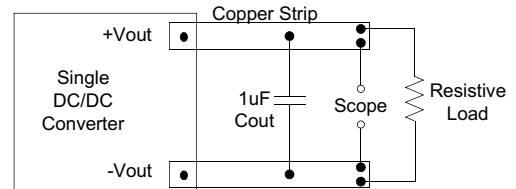

VV-245R1S12

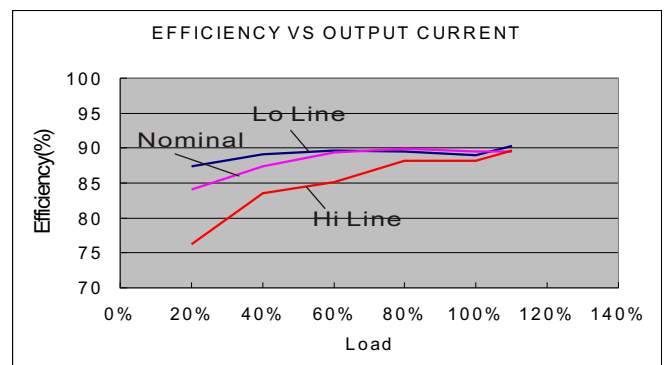

VV-4812S12

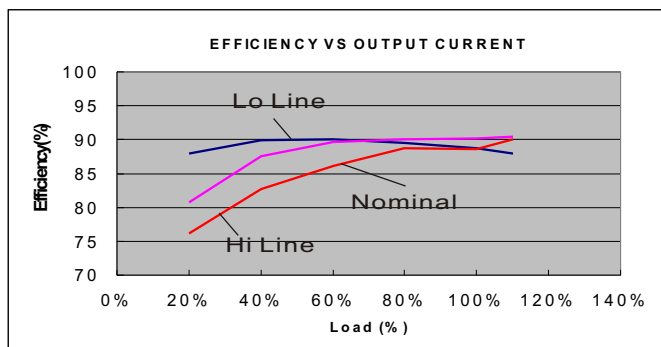

VV-2412D12

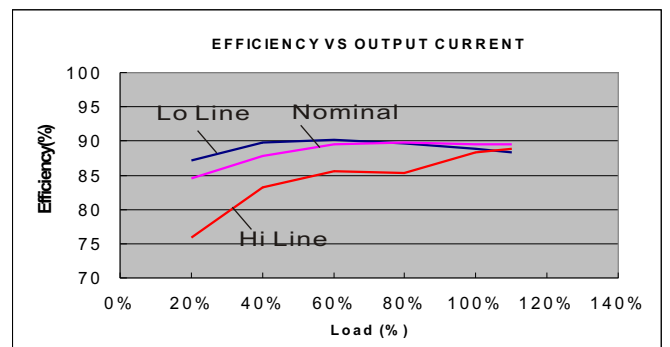

VV-4815D12

VV - 12W 4:1 Regulated Single & Dual output

MECHANICAL SPECIFICATIONS

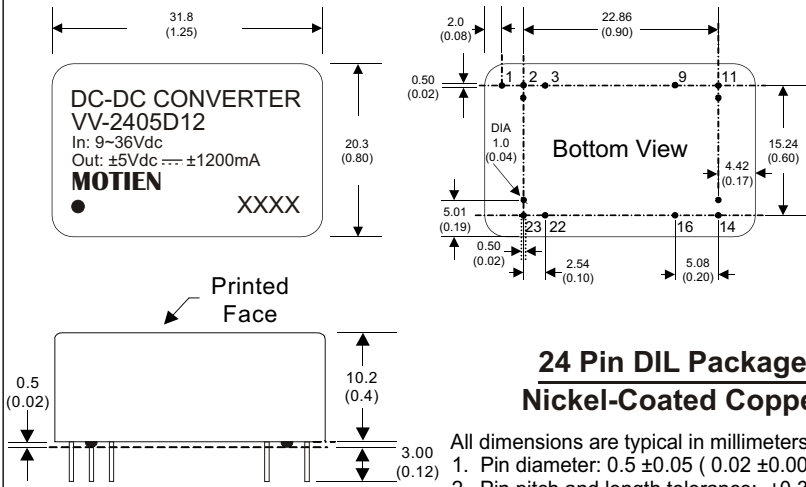

24 Pin DIL Package Nickel-Coated Copper

- All dimensions are typical in millimeters (inches).
1. Pin diameter: 0.5 ± 0.05 (0.02 ± 0.002)
 2. Pin pitch and length tolerance: ± 0.35 (± 0.014)
 3. Case Tolerance: ± 0.5 (± 0.02)
 4. Stand-off tolerance: ± 0.1 (± 0.004)

PIN CONNECTIONS		
PIN NUMBER	SINGLE	DUAL
1	Remote On/Off	Remote On/Off
2	-V Input	-V Input
3	-V Input	-V Input
9	N.P.	Common
11	N.C.	-V Output
14	+V Output	+V Output
16	-V Output	Common
22	+V Input	+V Input
23	+V Input	+V Input