

# QAE150 SERIES

## QUARTER-BRICK DC-DC CONVERTER

2:1 ULTRA WIDE INPUT RANGE  
UP TO 150Watts

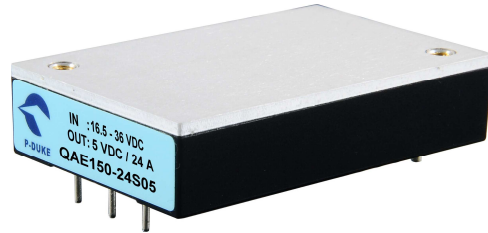

### FEATURES

- NO MINIMUM LOAD REQUIRED
- LOW STANDBY POWER CONSUMPTION
- 2250VDC INPUT TO OUTPUT BASIC INSULATION
- SAFETY MEETS UL60950-1, EN60950-1, & IEC60950-1
- CE MARKED
- COMPLIANT TO RoHS II & REACH

### APPLICATIONS

- WIRELESS NETWORK
- TELECOM/DATACOM
- INDUSTRY CONTROL SYSTEM
- DISTRIBUTED POWER ARCHITECTURES
- SEMICONDUCTOR EQUIPMENT

2250VDC ISOLATION	REMOTE CONTROL	UVP	OCP	SCP	OVP	OTP	LOW STANDBY POWER
-------------------	----------------	-----	-----	-----	-----	-----	-------------------

### TECHNICAL SPECIFICATION

All specifications are typical at nominal input, full load and 25°C otherwise noted

Model Number	Input Range	Output Voltage	Output Current @Full Load	Input Current @ No Load	Efficiency	Maximum Capacitor Load
	VDC	VDC	A	mA	%	µF
QAE150-12S3P3	8.5 ~ 22	3.3	30	50	89	91000
QAE150-12S05	8.5 ~ 22	5	24	50	90	48000
QAE150-12S12	8.5 ~ 22	12	10	50	91	8300
QAE150-12S15	8.5 ~ 22	15	8	50	91	5300
QAE150-12S24	8.5 ~ 22	24	5	50	90	2100
QAE150-12S30	8.5 ~ 22	30	4	50	90	1300
QAE150-12S48	8.5 ~ 22	48	2.5	50	89	520
QAE150-24S3P3	16.5 ~ 36	3.3	30	25	89	91000
QAE150-24S05	16.5 ~ 36	5	24	25	90	48000
QAE150-24S12	16.5 ~ 36	12	10	25	91	8300
QAE150-24S15	16.5 ~ 36	15	8	25	91	5300
QAE150-24S24	16.5 ~ 36	24	5	25	91	2100
QAE150-24S30	16.5 ~ 36	30	4	25	91	1300
QAE150-24S48	16.5 ~ 36	48	2.5	25	89	520
QAE150-48S3P3	33 ~ 75	3.3	30	15	89	91000
QAE150-48S05	33 ~ 75	5	25	15	91	50000
QAE150-48S12	33 ~ 75	12	12	15	90	10000
QAE150-48S15	33 ~ 75	15	10	15	90	6670
QAE150-48S24	33 ~ 75	24	6	15	92	2500
QAE150-48S30	33 ~ 75	30	5	15	91	1670
QAE150-48S48	33 ~ 75	48	3	15	92	630

### PART NUMBER STRUCTURE

<b>QAE150</b>	-	<b>48</b>	<b>S</b>	<b>05</b>	-	<b>P</b>	<b>HS</b>
Series Name		Input Voltage (VDC)	Output Quantity	Output Voltage (VDC)		Ctrl and Pin Options	Heat-sink and Mounting Hole Tread Options
		12:8.5~22 24:16.5~36 48:33~75	S:Single	3P3:3.3 05:5 12:12 15:15 24:24 30:30 48:48		□:Negative logic P:Positive logic	□:NC HS:H=0.24" Horizontal, 7G-0029A-F HS1:H=0.5" Horizontal, 7G-0030A-F HS2:H=0.24" Vertical, 7G-0031A-F HS3:H=0.5" Vertical, 7G-0032A-F TH:Through hole (No thread) <sup>(1)</sup>

(1) The module can't equip Heat-sink with TH option.

## INPUT SPECIFICATIONS

Parameter	Conditions		Min.	Typ.	Max.	Unit
Operating input voltage range	12Vin(nom)		8.5	12	22	VDC
	24Vin(nom)		16.5	24	36	
	48Vin(nom)		33	48	75	
Start-up voltage	12Vin(nom)		9			VDC
	24Vin(nom)		18			
	48Vin(nom)		36			
Shutdown voltage	12Vin(nom)		7.3	8.1		VDC
	24Vin(nom)		15.5	16.3		
	48Vin(nom)		31.6	32.5		
Start up time	Constant resistive load	Power up	75		100	ms
		Remote ON/OFF	75		100	
Input surge voltage	1 second, max.	12Vin(nom)	30			VDC
		24Vin(nom)	50			
		48Vin(nom)	100			
Input filter <sup>(1)</sup>			Pi type			
Remote ON/OFF	Referred to -Vin pin	Negative logic DC-DC ON	Short or 0 ~ 1.2 VDC			mA
		(Standard) DC-DC OFF	Open or 3 ~ 12 VDC			
		Positive logic DC-DC ON	Open or 3 ~ 12 VDC			mA
		(Option) DC-DC OFF	Short or 0 ~ 1.2 VDC			
		Input current of Ctrl pin	-0.5	1		
		Remote off input current	3			

## OUTPUT SPECIFICATIONS

Parameter	Conditions		Min.	Typ.	Max.	Unit
Voltage accuracy			-1.0	+1.0		%
Line regulation	Low Line to High Line at Full Load		-0.1	+0.1		%
Load regulation	No Load to Full Load	3.3 & 5Vout	-0.2	+0.2		%
		Others	-0.1	+0.1		
Voltage adjustability	Maximum output deviation is inclusive of remote sense		-20	+10		%
Remote sense	% of Vout(nom). If remote sense is not being used, sense pins should connect to the output pins with the same polarity.		10		%	
Ripple and noise	Measured by 20MHz bandwidth					
	With a 22µF/25V X7R MLCC	3.3Vout, 5Vout	75		mVp-p	
	With a 22µF/25V X7R MLCC	12Vout, 15Vout	100			
	With a 4.7µF/50V X7R MLCC	24Vout, 30Vout	200			
	With a 2.2µF/100V X7R MLCC	48Vout	300			
Temperature coefficient			-0.02	+0.02		
Transient response recovery time	25% load step change		250		µs	
Over voltage protection	% of Vout(nom); Hiccup mode		115	130		%
Over load protection	% of Iout rated; Hiccup mode		110	140		%
Short circuit protection			Continuous, automatic recovery			

## GENERAL SPECIFICATIONS

Parameter	Conditions		Min.	Typ.	Max.	Unit
Isolation voltage	1 minute (Basic insulation)	Input to Output	2250		VDC	
		Input (Output) to Base-Plate	2250			
Isolation resistance	500VDC		1		GΩ	
Isolation capacitance					1500 pF	
Switching frequency			270	300	330	kHz
Safety meets					UL60950-1 EN60950-1 IEC60950-1	
Case material			Aluminum base-plate with plastic case			
Potting material			Silicone (UL94 V-0)			
Weight			64g (2.26oz)			
MTBF	MIL-HDBK-217F, Full load		3.870 x 10 <sup>5</sup> hrs			

## ENVIRONMENTAL SPECIFICATIONS

Parameter	Conditions		Min.	Typ.	Max.	Unit
Operating base-plate temperature			-40	+100		°C
Over temperature protection			+110		°C	

Storage temperature range		-55	+125	°C
Thermal impedance (2)	Vertical direction by natural convection (20LFM)	Without Heat-sink Mount on 2U iron base-plate With 0.24" Height Heat-sink With 0.5" Height Heat-sink	9 2.8 7.1 5.5	°C/W
Thermal shock				MIL-STD-810F
Vibration				MIL-STD-810F
Relative humidity				5% to 95% RH

## EMC SPECIFICATIONS

Parameter	Conditions	Level
EMI (3)	EN55022	Class A Class B
ESD	EN61000-4-2 Air ± 8kV Contact ± 6kV	Perf. Criteria A
Radiated immunity	EN61000-4-3 20 V/m	Perf. Criteria A
Fast transient (4)	EN61000-4-4 ± 2kV	Perf. Criteria A
Surge (4)	EN61000-4-5 EN55024:±2kV	Perf. Criteria A
Conducted immunity	EN61000-4-6 10 Vr.m.s	Perf. Criteria A

### Note:

- Input source impedance: The power modules will operate as specifications without external components, assuming that the source voltage has a very low impedance and reasonable input voltage regulation. Highly inductive source impedances can affect the stability of the power module. Since real-world voltage source has finite impedance, performance can be improved by adding external filter capacitor. Recommended Nippon Chemi-con KY series, 100µF/100V.
- The heat-sink is optional and P/N: 7G-0029A-F, 7G-0030A-F, 7G-0031A-F, 7G-0032A-F. Please refer to heat-sink selection guide.
- The standard modules meet EMI Class A or Class B with external components. For further information, please contact with P-DUKE.
- An external input filter capacitor is required if the module has to meet EN61000-4-4, EN61000-4-5. Recommended 2 pcs of aluminum electrolytic capacitor (Nippon chemi-con KY series, 220µF/100V) to connect in parallel.
- BASE-PLATE GROUNDING: When connect two screw bolts to shield plane, the EMI could be reduced.

**CAUTION:** This power module is not internally fused. An input line fuse must always be used.

## CHARACTERISTIC CURVE

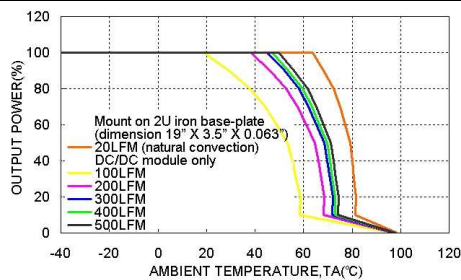

QAE150-48S05 Derating Curve

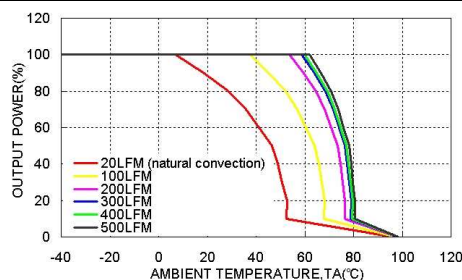

QAE150-48S05 Derating Curve With 0.24" Height Heat-sink

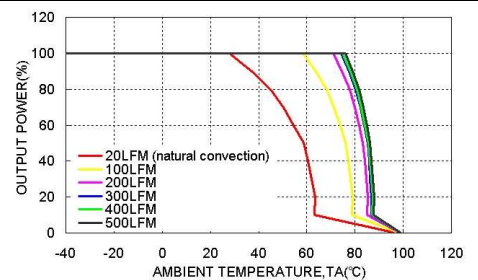

QAE150-48S05 Derating Curve With 0.5" Height Heat-sink

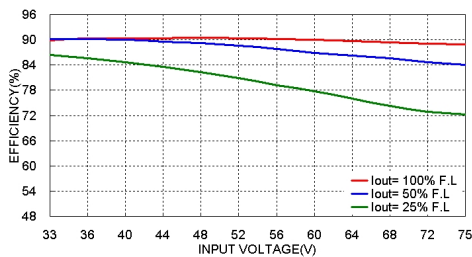

QAE150-48S05 Efficiency vs. Input Voltage

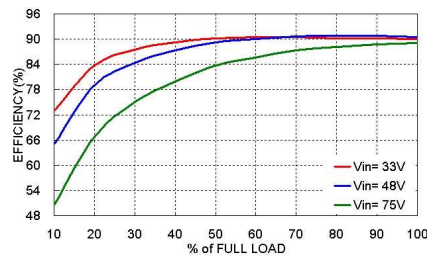

QAE150-48S05 Efficiency vs. Output Load

## MECHANICAL DRAWING

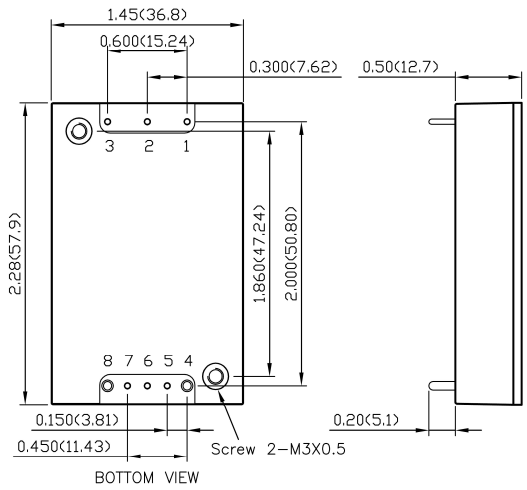

### PIN CONNECTION

PIN	DEFINE	DIAMETER
1	- Vin	0.04 Inch
2	Ctrl	0.04 Inch
3	+ Vin	0.04 Inch
4	- Vout	0.06 Inch
5	- Sense	0.04 Inch
6	Trim	0.04 Inch
7	+ Sense	0.04 Inch
8	+ Vout	0.06 Inch

### EXTERNAL OUTPUT TRIMMING

Output can be externally trimmed by using the method shown below.

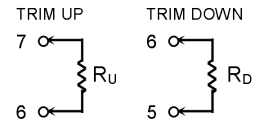

1. All dimensions in inch (mm)
2. Tolerance :x.xx±0.02 (x.x±0.5)  
x.xxx±0.01 (x.xx±0.25)
3. Pin pitch tolerance ±0.01 (0.25)
4. Pin dimension tolerance ±0.004(0.1)
5. The screw locked torque:  
MAX 3.5kgf-cm (0.34N-m)

$$R_U = \left( \frac{5.11V_{OUT}(100 + \Delta\%)}{1.225\Delta\%} - \frac{(511 + 10.22\Delta\%)}{\Delta\%} \right) k\Omega$$

$$R_D = \left( \frac{511}{\Delta\%} - 10.22 \right) k\Omega$$

## HEAT-SINK TYPE OPTIONS

7G-0029A-F

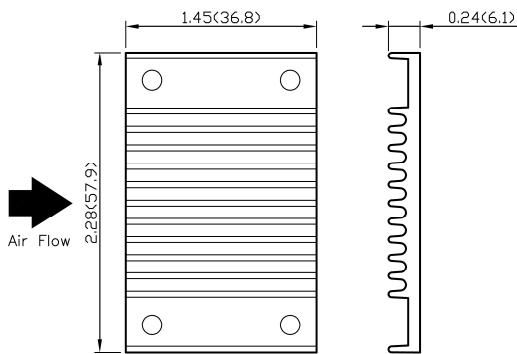

7G-0030A-F

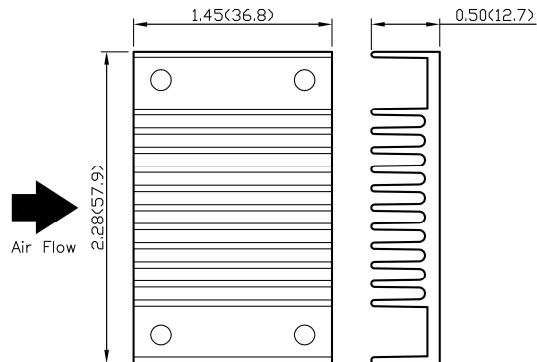

7G-0031A-F

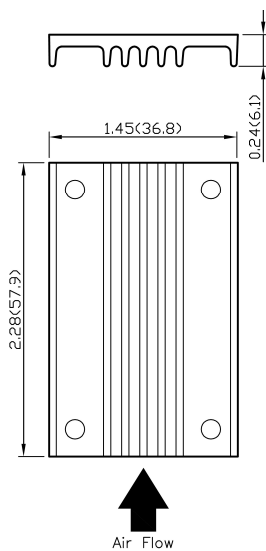

7G-0032A-F

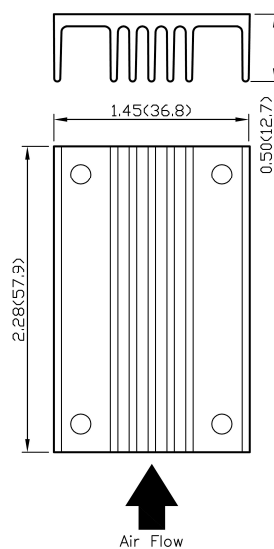

1. All dimensions in inch (mm)
2. Tolerance :x.xx±0.02 (x.x±0.5)