

# MAD40 SERIES

2 X 3 Inch AC-DC POWER SUPPLIES



UNIVERSAL INPUT RANGE  
 UP TO 40 WATTS



## FEATURES

- LOW STANDBY POWER CONSUMPTION UNDER 0.11 WATT
- WIDE INPUT VOLTAGE RANGE 85 TO 264VAC, 47 TO 63HZ
- BUILT-IN CLASS B EMI FILTER
- OUTPUT VOLTAGE ADJUSTABLE (SINGLE OUTPUT ONLY)
- 4000VAC INPUT TO OUTPUT 2MOPP INSULATION
- PROTECTION TYPE CLASS I AND CLASS II
- LOW LEAKAGE CURRENT UNDER 75µA
- OPERATING ALTITUDE 5000M
- 5 YEAR WARRANTY
- SAFETY MEETS ANSI/AAMI ES60601-1, EN60601-1 AND IEC60601-1 3<sup>rd</sup> EDITION
- CE MARKED
- COMPLIANT TO RoHS II & REACH

## APPLICATIONS

- MEDICAL EQUIPMENT
- WIRELESS NETWORK
- TELECOM/DATACOM
- INDUSTRY CONTROL SYSTEM
- MEASUREMENT EQUIPMENT
- SEMICONDUCTOR EQUIPMENT

4000VAC ISOLATION	OCP	SCP	OVP	LOW STANDBY POWER
-------------------	-----	-----	-----	-------------------

## TECHNICAL SPECIFICATION

All specifications are typical at 230VAC input, full load and 25°C otherwise noted

Model Number	Input Range	Output Voltage	Output Current @ Convection cooled 73°C Ta	Max. Output Power	Input Power @ No Load	Efficiency
	VAC	VDC	A	W	W	%
MAD40US05	85 ~ 264	5	8	40	0.11	90.0
MAD40US7P5	85 ~ 264	7.5	5.34	40	0.11	90.0
MAD40US09	85 ~ 264	9	4.45	40	0.11	91.0
MAD40US12	85 ~ 264	12	3.34	40	0.11	92.0
MAD40US121	85 ~ 264	12	3.34	40	0.11	90.0
MAD40US15	85 ~ 264	15	2.67	40	0.11	92.0
MAD40US151	85 ~ 264	15	2.67	40	0.11	90.5
MAD40US24	85 ~ 264	24	1.67	40	0.11	92.0
MAD40US28	85 ~ 264	28	1.43	40	0.11	91.0
MAD40US36	85 ~ 264	36	1.12	40	0.11	92.0
MAD40US48	85 ~ 264	48	0.84	40	0.13	93.0
MAD40US53	85 ~ 264	53	0.77	40	0.13	92.5

## PART NUMBER STRUCTURE

M	A	D	40	U	S	12	□
Application	Package Code	Dimension Code	Output Power (W)	Input Voltage (VAC)	Output Quantity	Output Voltage (VDC)	Protection Type
Medical	A: Open type			U: Universal	S: Single	05: 5	No suffix: CLASS I
Application	U: U chassis type			85 ~ 264		7P5: 7.5	B: CLASS II
	E: Enclosed type					09: 9	
	D: Din rail (E type only)					12: 12	
						15: 15	
						24: 24	
						28: 28	
						36: 36	
						48: 48	
						53: 53	

## INPUT SPECIFICATIONS

Parameter	Conditions	Min.	Typ.	Max.	Unit
Operating input voltage range	AC input	85		264	VAC
	DC input	120		370	VDC
Input frequency	AC input	47		63	Hz
Input current	100VAC and Full Load			1.0	A
	240VAC and Full Load			0.5	A
No load input power	230VAC			0.13	Watts
Leakage current	264VAC	48Vout, 53Vout		0.11	Watts
		Others		75	μA
Start up time				1000	ms
Rise time			20		ms
Hold up time	115VAC and Full Load		25		ms
Input inrush current	230VAC			60	A
Input protection	Internal fuse in line and neutral			T3.15A/250VAC	

## OUTPUT SPECIFICATIONS

Parameter	Conditions	Min.	Typ.	Max.	Unit
Output power				40	Watts
Initial set voltage accuracy	230VAC and Full Load	-1.0		+1.0	%
Line regulation	Low Line to High Line at Full Load	-0.2		+0.2	%
Load regulation	No Load to Full Load	5Vout		+0.7	%
		Others		+0.5	%
	10% Load to 90% Load	5Vout		+0.6	%
		Others		+0.4	%
Voltage adjustability	Single output	53Vout		+10	%
		Others		+10	%
Minimum load			0		%
Ripple and noise	Measured by 20MHz bandwidth With a 10μF/25V 1206 X7R MLCC	5Vout, 7.5Vout, 9Vout		75	mVp-p
		12Vout, 15Vout		75	mVp-p
		24Vout, 28Vout, 36Vout		75	mVp-p
		48Vout, 53Vout		150	mVp-p
Temperature coefficient		-0.02		+0.02	%/°C
Transient response	Load step form 50 ~ 75% change at 2.5A/μs			3	%Vout
	Peak deviation		600		μs
	Recovery time				μs
Over voltage protection	% of Vout(nom); Latch mode	125		140	%
Over load protection	% of Iout rated; Hiccup mode		145		%
Short circuit protection					Continuous, automatic recovery

## GENERAL SPECIFICATIONS

Parameter	Conditions	Min.	Typ.	Max.	Unit
Isolation voltage	1 minute (2MOPP insulation)	Input to Output	4000		VAC
		Input (Output) to F.G.	2500		VAC
Isolation resistance	500VDC	0.1			GΩ
Switching frequency	230VAC	5Vout		70	kHz
		Others		120	kHz
Safety meets					ANSI/AAMI ES60601-1 EN60601-1 IEC60601-1
Weight	MAD MUD MED MDD				114g (4.02oz)
					154g (5.43oz)
					169g (5.96oz)
					190g (6.70oz)
MTBF	MIL-HDBK-217F, Full load				3.010 x 10 <sup>5</sup> hrs

## ENVIRONMENTAL SPECIFICATIONS

Parameter	Conditions	Min.	Typ.	Max.	Unit
Operating ambient temperature	Natural convection	-40		+85	°C
Storage temperature range	With derating	-40		+85	°C
Operating altitude				5000	m
Shock					IEC68-2-27
Vibration					IEC68-2-6
Relative humidity	Non-condensing				5% to 95% RH

**EMC SPECIFICATIONS**

Parameter	Conditions			Level
EMI	EN55011, EN55022 and FCC Part 18			Conducted Class B Radiated Class B
Harmonic currents	EN61000-3-2	Full Load		Class A
Voltage flicker	EN61000-3-3			
ESD	EN61000-4-2	Air ± 8kV and Contact ± 6kV		Perf. Criteria A
Radiated immunity	EN61000-4-3	20 V/m		Perf. Criteria A
Fast transient	EN61000-4-4	± 2kV		Perf. Criteria A
Surge	EN61000-4-5	DM ± 1kV and CM ± 2kV		Perf. Criteria A
Conducted immunity	EN61000-4-6	20 Vr.m.s		Perf. Criteria A
Power frequency magnetic field	EN61000-4-8	10 A/m		Perf. Criteria A
Dip and interruptions	EN60601-1-2 EN61000-4-11	230VAC 50Hz	30% 500mS	Perf. Criteria A
			60% 100mS	Perf. Criteria A
			>95% 10mS	Perf. Criteria A
		100VAC 50Hz	>95% 5000mS	Perf. Criteria B
			30% 500mS	Perf. Criteria A
			60% 100mS	Perf. Criteria B
>95% 10mS	Perf. Criteria A			
>95% 5000mS	Perf. Criteria B			

**CHARACTERISTIC CURVE**

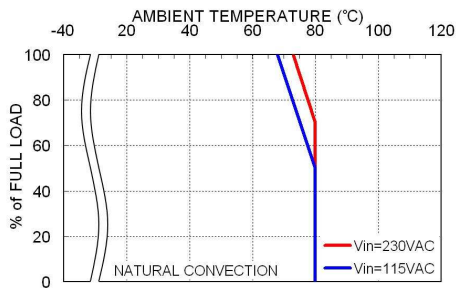

Derating Curve vs. Ambient Temperature  
MAD40US24

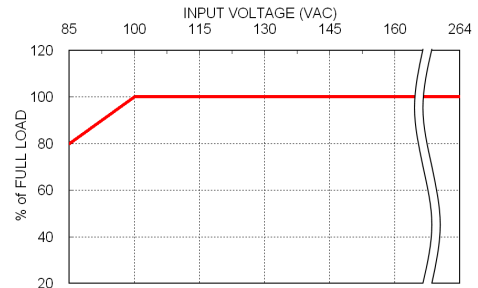

Derating Curve vs. Input Voltage

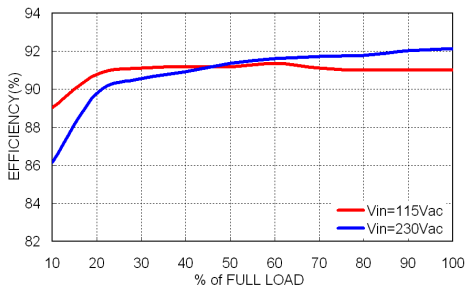

Efficiency vs. Output Load  
MAD40US24

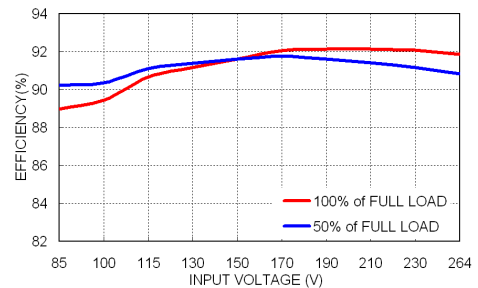

Efficiency vs. Input Voltage  
MAD40US24

**MECHANICAL DRAWING**

**MAD** Open type

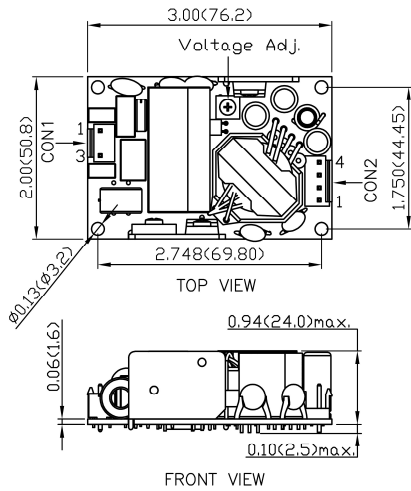

**MDD** Din rail type

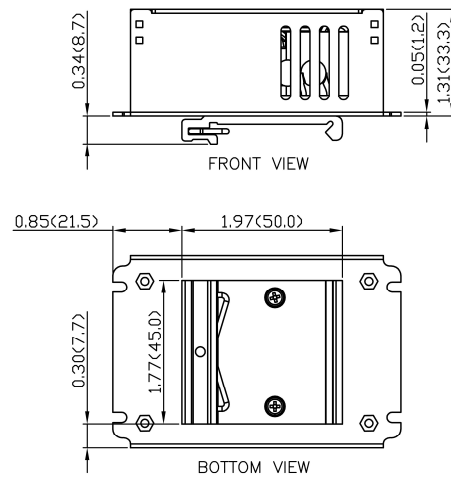

**MED** Enclosed type

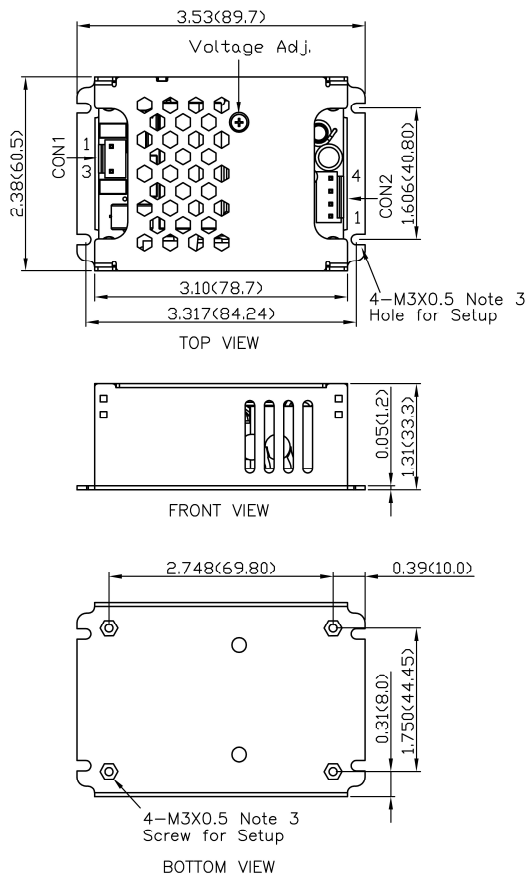

**MUD** U chassis type

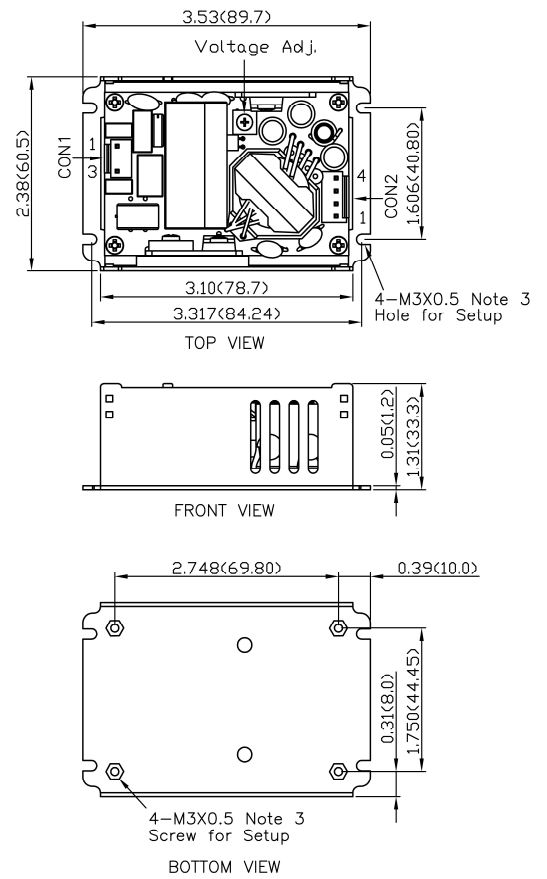

1. All dimensions in inch (mm)
2. Tolerance : x.xx±0.02 (x.x±0.5) x.xxx±0.01 (x.xx±0.25)
3. M3x0.5 screw locked torque MAX 5Kgf.cm/0.49N.m

**CONNECTORS CONNECTIONS**

**CON1 – Input Connector**

Pin 1	Line
Pin 3	Neutral

Mates with  
JST housing : **VHR-3N**  
JST crimp terminals : **SVH-21T-P1.1**

Mounting holes marked with ⊕ must be connected to safety earth for CLASS I application

**CON2 – Output Connector**

Pin 1,2	-Vout
Pin 3,4	+Vout

Mates with  
JST housing : **VHR-4N**  
JST crimp terminals : **SVH-21T-P1.1**