

CW SERIES

3W-6W WIDE INPUT RANGE

DANUBE

FEATURES

- 3W TO 6W DIL & SMD PACKAGE
- 4.5-9V,9-18V,18-36V,36-72V,9-36V,18-72V WIDE INPUT RANGE
- 100% BURN IN
- HIGH EFFICIENCY
- UL94-V0 PACKAGE MATERIAL
- CUSTOM SOLUTIONS AVAILABLE
- RoHS COMPLIANT
- 3 YEARS WARRANTY



OUTPUT SPECIFICATIONS

Voltage Setpoint Accuracy		
Single/Dual		+/-2% max.
Dual Separate	Out1	+/-2% max.
	Out2	+/-5% max.
Triple	Out1	+/-2% max.
	Out2/Out3	+/-5% max.
Temperature Coefficient		+/-0.05%/°C
Ripple & Noise(20MHz BW) ¹		100mVp-p max.
Line Regulation ²		
Single/Dual		+/-1% max.
Dual Separate	Out1	+/-1% max.
	Out2	+/-3% max.
Triple	Out1	+/-1% max.
	Out2/Out3	+/-3% max.
Load Regulation ⁴		
Single/Dual		+/-0.5% max.
	Output : 3.3V	+/-1% max.
Dual Separate	Out1	+/-1% max.
	Out2	+/-5% max.
Triple	Out1	+/-1% max.
	Out2/Out3	+/-5% max.
Minimum Load	20% of Full Load	
Short Circuit Protection	Continuous	
Short Circuit Restart	Automatic	
Over Load Protection	3W~6W	110%~180%
Transient Response ⁶		200uS max.
Capacitive Load	5V:1000uF	max.
	12V:470uF	max.
	15V: 330uF	max.
	Other Output: ±220uF	max.

INPUT SPECIFICATIONS

Input Voltage Range	2:1 or 4:1 Input Range
Input Filter	Pi Network
Protection	Fuse Recommended
Remote ON/OFF Control	Table 1
Start up Time(Nominal Input)	50mS max.

GENERAL SPECIFICATIONS

Efficiency	70% min.	
Isolation Voltage ³		
Single/Dual/Triple	1500VDC or 3000VDC min.	
Dual Separate	In to Out	1500VDC min.
	Out1 to Out2	500VDC min.
Isolation Resistance	10 ⁹ ohms min.	
Isolation Capacitance	40pF max.	
Switching Frequency	50KHz min.	
MTBF ⁵	>900,000 Hours	
Weight	17.5g Typ.	
Case Material	Five-Side Shielded Case	
Case Size(DIL)	31.8mm*20.3mm*12.2mm	
Case Size(SMD)	31.8mm*20.3mm*11.4mm	
Potting Material(DIL)	Epoxy(UL94-V0)	
Potting Material(SMD)	Non potting	
Conducted Emissions	EN55022 Class A	
Radiated Emissions	EN55022 Class B	

ENVIRONMENTAL SPECIFICATIONS

Operating Temperature	-40 °C to +71 °C
Storage Temperature	-55 °C to +125 °C
Case Temperature	+95 °C max.
Humidity	95% max.
Cooling	Free-Air Convection

ALL SPECIFICATIONS TYPICAL AT NOMINAL LINE, FULL LOAD , AND 25 °C UNLESS OTHERWISE NOTED.

¹ Measured with 1uF ceramic capacitor connect to the output pins.

² High Line to Low Line.

³ 1500VDC for 10 seconds,2000VDC~3000VDC for 3 seconds.

⁴ Load Regulation is for output load current change from 20% to 100%.

⁵ MIL-HDBK-217F @25 °C , Ground Benign.

⁶ 25% Step Load Change.

● **SELECTION GUIDE(1)**
2:1 3W OUTPUT 1500VDC ISOLATION

MODEL NUMBER	INPUT VOLTAGE (VDC)	OUTPUT VOLTAGE (VDC)	OUTPUT CURRENT (mA)	INPUT ⁷ CURRENT(mA)		EFF (%) ⁸	ISOLATION (VDC)
				FULL LOAD	NO LOAD		
CWS-0503.3(ABC)3M	4.5-9	3.3	755	683	40	73	1500
CWS-0505(ABCD)3M	4.5-9	5	500	685	40	73	1500
CWS-0512(ABCD)3M	4.5-9	12	250	789	40	76	1500
CWS-0515(ABCD)3M	4.5-9	15	200	789	40	76	1500
CWD-0505A3M	4.5-9	+/-5	+/-300	855	40	70	1500
CWD-0512(ABC)3M	4.5-9	+/-12	+/-125	810	40	74	1500
CWD-0515(ABC)3M	4.5-9	+/-15	+/-100	800	60	75	1500
CWS-1203.3(ABCD)3M	9-18	3.3	700	275	18	70	1500
CWS-1205(ABCD)3M	9-18	5	600	338	18	74	1500
CWS-1209(ABCD)3M	9-18	9	330	313	18	79	1500
CWS-1212(ABCD)3M	9-18	12	250	313	18	80	1500
CWS-1215(ABCD)3M	9-18	15	200	313	18	80	1500
CWS-1224(ABCD)3M	9-18	24	125	313	18	80	1500
CWD-1205(ABC)3M	9-18	+/-5	+/-300	338	18	74	1500
CWD-1212(ABC)3M	9-18	+/-12	+/-125	316	30	79	1500
CWD-1215(ABC)3M	9-18	+/-15	+/-100	316	32	79	1500
CWS-2403.3(ABCD)3M	18-36	3.3	910	163	10	76	1500
CWS-2405(ABCD)3M	18-36	5	600	167	10	75	1500
CWS-2409(ABCD)3M	18-36	9	330	158	10	79	1500
CWS-2412(ABCD)3M	18-36	12	250	156	10	80	1500
CWS-2415(ABCD)3M	18-36	15	200	156	10	80	1500
CWS-2424(ABCD)3M	18-36	24	125	156	10	80	1500
CWD-2405(ABC)3M	18-36	+/-5	+/-300	167	10	75	1500
CWD-2412(ABC)3M	18-36	+/-12	+/-125	156	15	80	1500
CWD-2415(ABC)3M	18-36	+/-15	+/-100	156	25	80	1500
CWS-4803.3(ABCD)3M	36-72	3.3	700	69	5	72	1500
CWS-4805(ABCD)3M	36-72	5	600	82	5	76	1500
CWS-4809(ABCD)3M	36-72	9	330	79	5	79	1500
CWS-4812(ABCD)3M	36-72	12	250	78	5	80	1500
CWS-4815(ABCD)3M	36-72	15	200	76	5	82	1500
CWS-4824(ABCD)3M	36-72	24	125	76	5	82	1500
CWD-4805(ABC)3M	36-72	+/-5	+/-300	82	5	76	1500
CWD-4812(ABC)3M	36-72	+/-12	+/-125	80	5	78	1500
CWD-4815(ABC)3M	36-72	+/-15	+/-100	79	5	79	1500

Note: Other input to output voltages may be available. Please contact factory.

ORDERING INFORMATION:

FOR EXAMPLE: CWS-1205A3M (A PACKAGE 3W SINGLE OUTPUT)
CWD-2405B3M (B PACKAGE 3W DUAL OUTPUT)

⁷ NOMINAL INPUT VOLTAGE.

⁸ NOMINAL INPUT VOLTAGE, FULL LOAD.

● **SELECTION GUIDE(2)**
4:1 3W OUTPUT 1500VDC ISOLATION

MODEL NUMBER	INPUT VOLTAGE (VDC)	OUTPUT VOLTAGE (VDC)	OUTPUT CURRENT (mA)	INPUT ⁹ CURRENT(mA)		EFF (%) ¹⁰	ISOLATION (VDC)
				FULL LOAD	NO LOAD		
CWS-1203.3(ABC)3TM	9-36	3.3	700	283	20	68	1500
CWS-1205(ABC)3TM	9-36	5	600	347	18	72	1500
CWS-1212(ABC)3TM	9-36	12	250	321	18	78	1500
CWS-1215(ABC)3TM	9-36	15	200	321	18	78	1500
CWS-1224(ABC)3TM	9-36	24	125	321	20	78	1500
CWD-1205(ABC)3TM	9-36	+/-5	+/-300	333	18	75	1500
CWD-1212(ABC)3TM	9-36	+/-12	+/-125	320	18	78	1500
CWD-1215(ABC)3TM	9-36	+/-15	+/-100	320	18	78	1500
CWS-2403.3(ABC)3TM	18-72	3.3	700	136	10	71	1500
CWS-2405(ABC)3TM	18-72	5	600	169	10	74	1500
CWS-2412(ABC)3TM	18-72	12	250	160	10	78	1500
CWS-2415(ABC)3TM	18-72	15	200	156	10	80	1500
CWS-2424(ABC)3TM	18-72	24	125	160	10	78	1500
CWD-2405(ABC)3TM	18-72	+/-5	+/-300	169	10	74	1500
CWD-2409(ABC)3TM	18-72	+/-9	+/-167	158	10	79	1500
CWD-2412(ABC)3TM	18-72	+/-12	+/-125	160	10	78	1500
CWD-2415(ABC)3TM	18-72	+/-15	+/-100	160	15	78	1500

Note: Other input to output voltages may be available. Please contact factory.

ORDERING INFORMATION:

FOR EXAMPLE: CWS-1205A3TM (A PACKAGE 3W SINGLE OUTPUT)

CWD-2405B3TM (B PACKAGE 3W DUAL OUTPUT)

⁹ NOMINAL INPUT VOLTAGE.

¹⁰ NOMINAL INPUT VOLTAGE, FULL LOAD.

● **SELECTION GUIDE(3)**
2:1 3W OUTPUT 2000VDC ISOLATION

MODEL NUMBER	INPUT VOLTAGE (VDC)	OUTPUT VOLTAGE (VDC)	OUTPUT CURRENT (mA)	INPUT ¹¹ CURRENT(mA)		EFF (%) ¹²	ISOLATION (VDC)
				FULL LOAD	NO LOAD		
CWS-0505P3(M)	4.5-9	5	500	685	40	73	2000
CWS-0512P3(M)	4.5-9	12	250	821	40	73	2000
CWS-0515P3(M)	4.5-9	15	200	789	40	76	2000
CWS-1203.3P3(M)	9-18	3.3	910	358	18	70	2000
CWS-1205P3(M)	9-18	5	600	338	18	74	2000
CWS-1209P3(M)	9-18	9	330	313	18	79	2000
CWS-1212P3(M)	9-18	12	250	313	18	80	2000
CWS-1215P3(M)	9-18	15	200	313	18	80	2000
CWS-2403.3P3(M)	18-36	3.3	910	163	10	76	2000
CWS-2405P2.5(M)	18-36	5	500	143	10	73	2000
CWS-2405P3(M)	18-36	5	600	167	10	75	2000
CWS-2409P3(M)	18-36	9	330	158	10	79	2000
CWS-2412P3(M)	18-36	12	250	156	10	80	2000
CWS-2415P3(M)	18-36	15	200	156	10	80	2000
CWS-4803.3P3(M)	36-72	3.3	910	87	5	72	2000
CWS-4805P3(M)	36-72	5	600	82	5	76	2000
CWS-4809P3(M)	36-72	9	330	79	5	79	2000
CWS-4812P3(M)	36-72	12	250	76	5	82	2000
CWS-4815P3(M)	36-72	15	200	76	5	82	2000

Note: Other input to output voltages may be available. Please contact factory.

ORDERING INFORMATION:

FOR EXAMPLE: CWS-1205P3M (P PACKAGE 3W SINGLE OUTPUT)

¹¹ NOMINAL INPUT VOLTAGE.

¹² NOMINAL INPUT VOLTAGE, FULL LOAD.

● **SELECTION GUIDE(4)**
2:1 4W-6W OUTPUT 1500VDC ISOLATION

MODEL NUMBER	INPUT VOLTAGE (VDC)	OUTPUT VOLTAGE (VDC)	OUTPUT CURRENT (mA)	INPUT ¹³		EFF (%) ¹⁴	ISOLATION (VDC)
				CURRENT(mA)			
				FULL LOAD	NO LOAD		
CWS-0505(AB)5M	4.5-9	5	800	1081	40	74	1500
CWS-0512(AB)5M	4.5-9	12	333	1066	40	75	1500
CWS-0515(AB)5M	4.5-9	15	267	1068	40	75	1500
CWD-0505(AB)5M	4.5-9	+/-5	+/-400	1125	40	71	1500
CWD-0512(AB)5M	4.5-9	+/-12	+/-167	1073	120	75	1500
CWD-0515(AB)5M	4.5-9	+/-15	+/-133	1060	100	75	1500
CWS-1203.3(AB)5M	9-18	3.3	1200	438	40	75	1500
CWS-1205(AB)5M	9-18	5	1000	556	40	75	1500
CWS-1209(AB)5M	9-18	9	556	520	40	80	1500
CWS-1212(AB)5M	9-18	12	470	587	40	80	1500
CWS-1215(AB)5M	9-18	15	400	617	41	81	1500
CWS-1224(AB)5M	9-18	24	208	520	41	80	1500
CWD-1205(AB)5M	9-18	+/-5	+/-500	556	40	75	1500
CWD-1209(AB)5M	9-18	+/-9	+/-280	525	20	80	1500
CWD-1212(AB)5M	9-18	+/-12	+/-230	585	40	79	1500
CWD-1215(AB)5M	9-18	+/-15	+/-190	586	48	81	1500
CWS-2403.3(AB)5M	18-36	3.3	1200	217	20	76	1500
CWS-2405(AB)5M	18-36	5	1000	270	20	77	1500
CWS-2409(AB)5M	18-36	9	556	257	20	81	1500
CWS-2412(AB)5M	18-36	12	470	292	22	80	1500
CWS-2415(AB)5M	18-36	15	400	301	21	83	1500
CWS-2424(AB)5M	18-36	24	208	260	21	80	1500
CWD-2405(AB)5M	18-36	+/-5	+/-500	270	20	77	1500
CWD-2412(AB)5M	18-36	+/-12	+/-230	279	20	82	1500
CWD-2415(AB)5M	18-36	+/-15	+/-190	286	21	83	1500
CWS-4803.3(AB)5M	36-72	3.3	1200	108	10	76	1500
CWS-4805(AB)5M	36-72	5	1000	135	10	77	1500
CWS-4809(AB)5M	36-72	9	556	130	9	80	1500
CWS-4812(AB)5M	36-72	12	470	142	9	83	1500
CWS-4815(AB)5M	36-72	15	400	154	10	81	1500
CWS-4824(AB)5M	36-72	24	208	130	10	80	1500
CWD-4805(AB)5M	36-72	+/-5	+/-500	135	10	77	1500
CWD-4812(AB)5M	36-72	+/-12	+/-230	144	12	80	1500
CWD-4815(AB)5M	36-72	+/-15	+/-190	146	10	81	1500

Note: Other input to output voltages may be available. Please contact factory.

ORDERING INFORMATION:

FOR EXAMPLE: CWS-1205A5M (A PACKAGE 5W SINGLE OUTPUT)

CWD-1205B5M (B PACKAGE 5W DUAL OUTPUT)

¹³ NOMINAL INPUT VOLTAGE.

¹⁴ NOMINAL INPUT VOLTAGE, FULL LOAD.

● **SELECTION GUIDE(5)**
4:1 4W-5W OUTPUT 1500VDC ISOLATION

MODEL NUMBER	INPUT VOLTAGE (VDC)	OUTPUT VOLTAGE (VDC)	OUTPUT CURRENT (mA)	INPUT ¹⁵		EFF (%) ¹⁶	ISOLATION (VDC)
				CURRENT(mA)			
				FULL LOAD	NO LOAD		
CWS-1203.3A5TM	9-36	3.3	1200	471	40	70	1500
CWS-1205A5TM	9-36	5	1000	548	40	76	1500
CWS-1209A5TM	9-36	9	556	542	40	77	1500
CWS-1212A5TM	9-36	12	417	542	20	77	1500
CWS-1215A5TM	9-36	15	333	534	20	78	1500
CWD-1205A5TM	9-36	+/-5	+/-500	563	40	74	1500
CWD-1212A5TM	9-36	+/-12	+/-208	533	40	78	1500
CWD-1215A5TM	9-36	+/-15	+/-167	535	40	78	1500
CWS-2403.3A5TM	18-72	3.3	1200	229	20	72	1500
CWS-2405A5TM	18-72	5	1000	271	20	77	1500
CWS-2409A5TM	18-72	9	556	264	20	79	1500
CWS-2412A5TM	18-72	12	417	264	20	79	1500
CWS-2415A5TM	18-72	15	333	260	20	80	1500
CWD-2405A5TM	18-72	+/-5	+/-500	280	20	74	1500
CWD-2412A5TM	18-72	+/-12	+/-208	270	10	77	1500
CWD-2415A5TM	18-72	+/-15	+/-167	260	10	80	1500

Note: Other input to output voltages may be available. Please contact factory.

ORDERING INFORMATION:

FOR EXAMPLE: CWS-2405A5TM (A PACKAGE 5W SINGLE OUTPUT)
CWD-2405A5TM (A PACKAGE 5W DUAL OUTPUT)

¹⁵ NOMINAL INPUT VOLTAGE.

¹⁶ NOMINAL INPUT VOLTAGE, FULL LOAD.

● **SELECTION GUIDE(6)**
2:1 or 4:1 3W~5W DUAL SEPARATE OUTPUT

MODEL NUMBER	INPUT VOLTAGE (VDC)	OUTPUT VOLTAGE (VDC)	OUTPUT CURRENT (mA)	INPUT ¹⁷		EFF (%) ¹⁸	ISOLATION (VDC)
				CURRENT(mA)			
				FULL LOAD	NO LOAD		
CWD-120505E3TM	9-36	V1:5V V2:5V	V1:300 V2:300	348	40	72	1500
CWD-120505E5TM	9-36	V1:5V V2:5V	V1:450 V2:450	520	40	72	1500
CWD-121515E3M	9-18	V1:15V V2:15V	V1:100 V2:100	348	40	72	1500
CWD-121515E5TM	9-36	V1:15V V2:15V	V1:150 V2:150	510	40	74	1500
CWD-122424E5TM	9-36	V1:24V V2:24V	V1:95 V2:95	510	40	74	1500
CWD-241212E5M	18-36	V1:12V V2:12V	V1:188 V2:188	241	25	78	1500
CWD-241515E3M	18-36	V1:15V V2:15V	V1:100 V2:100	169	16	74	1500
CWD-240505E3TM	18-72	V1:5V V2:5V	V1:300 V2:300	169	15	74	1500
CWD-481212E3M	36-72	V1:12V V2:12V	V1:125 V2:125	83	10	75	1500

Note: Other input to output voltages may be available. Please contact factory.

ORDERING INFORMATION:

FOR EXAMPLE: CWD-121515E3M (E PACKAGE 3W DUAL OUTPUT)
CWD-241212E5M (E PACKAGE 5W DUAL OUTPUT)

¹⁷ NOMINAL INPUT VOLTAGE.

¹⁸ NOMINAL INPUT VOLTAGE, FULL LOAD.

● **SELECTION GUIDE(7)**
2:1 or 4:1 3W DUAL SEPARATE OUTPUT

MODEL NUMBER	INPUT VOLTAGE (VDC)	OUTPUT VOLTAGE (VDC)	OUTPUT CURRENT (mA)	INPUT ¹⁹ CURRENT(mA)		EFF (%) ²⁰	ISOLATION (VDC)
				FULL LOAD	NO LOAD		
CWD-121515F3M	9-18	V1:15V V2:15V	V1:100 V2:100	315	33	79	1500
CWD-120505F3TM	9-36	V1:5V V2:5V	V1:300 V2:300	338	35	74	1500
CWD-121212F3TM	9-36	V1:12V V2:12V	V1:125 V2:125	331	33	76	1500
CWD-121515F3TM	9-36	V1:15V V2:15V	V1:100 V2:100	320	20	78	1500
CWD-122424F3TM	9-36	V1:24V V2:24V	V1:63 V2:63	318	20	79	1500
CWD-240505F3TM	18-72	V1:5V V2:5V	V1:300 V2:300	169	15	74	1500
CWD-241212F3M	18-36	V1:12V V2:12V	V1:125 V2:125	156	15	80	1500
CWD-241212F3TM	18-72	V1:12V V2:12V	V1:125 V2:125	156	15	80	1500
CWD-241515F3TM	18-72	V1:15V V2:15V	V1:100 V2:100	156	15	80	1500
CWD-242424F3TM	18-72	V1:24V V2:24V	V1:63 V2:63	152	15	82	1500

Note: Other input to output voltages may be available. Please contact factory.

ORDERING INFORMATION:

FOR EXAMPLE: CWD-242424F3TM (F PACKAGE 3W DUAL OUTPUT)

¹⁹ NOMINAL INPUT VOLTAGE.

²⁰ NOMINAL INPUT VOLTAGE, FULL LOAD.

● **SELECTION GUIDE(8)**
2:1 4W TRIPLE OUTPUT

MODEL NUMBER	INPUT VOLTAGE (VDC)	OUTPUT VOLTAGE (VDC)			OUTPUT CURRENT (mA)			INPUT ²¹ CURRENT (mA)		EFF (%) ²²	ISOLATION (VDC)
		OUT1	OUT2	OUT3	OUT1	OUT2	OUT3	FULL LOAD	NO LOAD		
CWT-0505-12	4.5-9	+5	+12V	-12V	300	100	100	1085	20	74	1500
CWT-0505-15	4.5-9	+5	+15	-15	300	80	80	1280	20	70	1500
CWT-1205-12	9-18	+5	+12V	-12V	300	100	100	406	20	80	1500
CWT-1205-15	9-18	+5	+15	-15	300	80	80	450	20	74	1500
CWT-2405-12	18-36	+5	+12V	-12V	300	100	100	200	20	81	1500
CWT-2405-15	18-36	+5	+15	-15	300	80	80	225	20	74	1500
CWT-4805-12	36-72	+5	+12V	-12V	300	100	100	114	20	73	1500
CWT-4805-15	36-72	+5	+15	-15	300	80	80	113	20	74	1500

Note: Other input to output voltages may be available. Please contact factory.

ORDERING INFORMATION:

FOR EXAMPLE: CWT-1205-15 (T PACKAGE 4W TRIPLE OUTPUT)

²¹ NOMINAL INPUT VOLTAGE.

²² NOMINAL INPUT VOLTAGE, FULL LOAD.

● **SELECTION GUIDE(9)**
2:1 3W OUTPUT 3000VDC ISOLATION

MODEL NUMBER	INPUT VOLTAGE (VDC)	OUTPUT VOLTAGE (VDC)	OUTPUT CURRENT (mA)	INPUT ²³		EFF (%) ²⁴	ISOLATION (VDC) ²⁵
				CURRENT(mA)			
				FULL LOAD	NO LOAD		
CWS-0503.3A3M-3K	4.5-9	3.3	755	683	40	73	3000
CWS-0505A3M-3K	4.5-9	5	500	684	40	73	3000
CWS-0512A3M-3K	4.5-9	12	250	789	40	76	3000
CWS-0515A3M-3K	4.5-9	15	200	789	40	76	3000
CWS-1203.3A3M-3K	9-18	3.3	700	275	18	70	3000
CWS-1205A3M-3K	9-18	5	600	338	18	74	3000
CWS-1209A3M-3K	9-18	9	330	316	18	79	3000
CWS-1212A3M-3K	9-18	12	250	313	18	80	3000
CWS-1215A3M-3K	9-18	15	200	313	18	80	3000
CWD-1205A3M-3K	9-18	+/-5	+/-300	338	18	74	3000
CWD-1212A3M-3K	9-18	+/-12	+/-125	316	18	79	3000
CWD-1215A3M-3K	9-18	+/-15	+/-100	316	18	79	3000
CWS-2403.3A3M-3K	18-36	3.3	910	163	10	77	3000
CWS-2405A3M-3K	18-36	5	600	167	10	75	3000
CWS-2409A3M-3K	18-36	9	330	158	10	79	3000
CWS-2412A3M-3K	18-36	12	250	156	10	80	3000
CWS-2415A3M-3K	18-36	15	200	156	10	80	3000
CWS-2424A3M-3K	18-36	24	125	154	10	81	3000
CWD-2405A3M-3K	18-36	+/-5	+/-300	167	10	75	3000
CWD-2412A3M-3K	18-36	+/-12	+/-125	156	10	80	3000
CWD-2415A3M-3K	18-36	+/-15	+/-100	156	25	80	3000
CWS-4803.3A3M-3K	36-72	3.3	700	69	5	72	3000
CWS-4805A3M-3K	36-72	5	600	82	5	76	3000
CWS-4809A3M-3K	36-72	9	330	79	5	79	3000
CWS-4812A3M-3K	36-72	12	250	78	5	80	3000
CWS-4815A3M-3K	36-72	15	200	76	5	82	3000
CWD-4805A3M-3K	36-72	+/-5	+/-300	82	5	76	3000
CWD-4812A3M-3K	36-72	+/-12	+/-125	80	5	78	3000
CWD-4815A3M-3K	36-72	+/-15	+/-100	79	5	79	3000

Note: Other input to output voltages may be available. Please contact factory.

ORDERING INFORMATION:

FOR EXAMPLE: CWS-1205A3M-3K (A PACKAGE 3W SINGLE OUTPUT)

CWD-2405A3M-3K (A PACKAGE 3W DUAL OUTPUT)

²³ NOMINAL INPUT VOLTAGE.

²⁴ NOMINAL INPUT VOLTAGE, FULL LOAD.

²⁵ FOR 3 SECONDS.

● **SELECTION GUIDE(10)**
4:1 3W OUTPUT 3000VDC ISOLATION

MODEL NUMBER	INPUT VOLTAGE (VDC)	OUTPUT VOLTAGE (VDC)	OUTPUT CURRENT (mA)	INPUT ²⁶		EFF (%) ²⁷	ISOLATION (VDC) ²⁸
				CURRENT(mA)			
				FULL LOAD	NO LOAD		
CWS-1203.3A3TM-3K	9-36	3.3	700	285	20	68	3000
CWS-1205A3TM-3K	9-36	5	600	338	18	74	3000
CWS-1209A3TM-3K	9-36	9	330	320	18	77	3000
CWS-1212A3TM-3K	9-36	12	250	320	18	78	3000
CWS-1215A3TM-3K	9-36	15	200	320	18	78	3000
CWD-1205A3TM-3K	9-36	+/-5	+/-300	333	18	75	3000
CWD-1212A3TM-3K	9-36	+/-12	+/-125	320	18	78	3000
CWD-1215A3TM-3K	9-36	+/-15	+/-100	320	18	78	3000
CWS-2403.3A3TM-3K	18-72	3.3	700	136	10	71	3000
CWS-2405A3TM-3K	18-72	5	600	169	10	74	3000
CWS-2409A3TM-3K	18-72	9	330	158	10	79	3000
CWS-2412A3TM-3K	18-72	12	250	156	10	80	3000
CWS-2415A3TM-3K	18-72	15	200	156	10	80	3000
CWD-2405A3TM-3K	18-72	+/-5	+/-300	169	10	74	3000
CWD-2412A3TM-3K	18-72	+/-12	+/-125	160	10	78	3000
CWD-2415A3TM-3K	18-72	+/-15	+/-100	160	10	78	3000

Note: Other input to output voltages may be available. Please contact factory.

ORDERING INFORMATION:

FOR EXAMPLE: CWS-1205A3TM-3K (A PACKAGE 3W SINGLE OUTPUT)
CWD-2405A3TM-3K (A PACKAGE 3W DUAL OUTPUT)

²⁶ NOMINAL INPUT VOLTAGE.

²⁷ NOMINAL INPUT VOLTAGE, FULL LOAD.

²⁸ FOR 3 SECONDS.

● **SELECTION GUIDE(11)**
2:1 4W-6W OUTPUT 3000VDC ISOLATION

MODEL NUMBER	INPUT VOLTAGE (VDC)	OUTPUT VOLTAGE (VDC)	OUTPUT CURRENT (mA)	INPUT ²⁹ CURRENT(mA)		EFF (%) ³⁰	ISOLATION (VDC) ³¹
				FULL LOAD	NO LOAD		
CWS-0505A5M-3K	4.5-9	5	800	1081	40	74	3000
CWS-1203.3A5M-3K	9-18	3.3	1200	438	40	75	3000
CWS-1205A5M-3K	9-18	5	1000	556	40	75	3000
CWS-1209A5M-3K	9-18	9	556	520	40	80	3000
CWS-1212A5M-3K	9-18	12	470	587	40	80	3000
CWS-1215A5M-3K	9-18	15	400	617	30	81	3000
CWD-1205A5M-3K	9-18	+/-5	+/-500	556	40	75	3000
CWD-1212A5M-3K	9-18	+/-12	+/-230	585	40	79	3000
CWD-1215A5M-3K	9-18	+/-15	+/-190	586	41	81	3000
CWS-2403.3A5M-3K	18-36	3.3	1200	217	20	76	3000
CWS-2405A5M-3K	18-36	5	1000	270	20	77	3000
CWS-2409A5M-3K	18-36	9	556	257	20	81	3000
CWS-2412A5M-3K	18-36	12	470	287	22	82	3000
CWS-2415A5M-3K	18-36	15	400	301	21	83	3000
CWD-2405A5M-3K	18-36	+/-5	+/-500	270	20	77	3000
CWD-2412A5M-3K	18-36	+/-12	+/-230	279	20	82	3000
CWD-2415A5M-3K	18-36	+/-15	+/-190	286	21	83	3000
CWS-4803.3A5M-3K	36-72	3.3	1200	112	10	74	3000
CWS-4805A5M-3K	36-72	5	1000	135	10	77	3000
CWS-4809A5M-3K	36-72	9	556	126	9	83	3000
CWS-4812A5M-3K	36-72	12	470	146	9	80	3000
CWS-4815A5M-3K	36-72	15	400	147	10	85	3000
CWD-4805A5M-3K	36-72	+/-5	+/-500	135	10	77	3000
CWD-4812A5M-3K	36-72	+/-12	+/-230	138	12	83	3000
CWD-4815A5M-3K	36-72	+/-15	+/-190	146	10	81	3000

Note: Other input to output voltages may be available. Please contact factory.

ORDERING INFORMATION:

FOR EXAMPLE: CWS-1205A5M-3K (A PACKAGE 5W SINGLE OUTPUT)
CWD-2405A5M-3K (A PACKAGE 5W DUAL OUTPUT)

²⁹ NOMINAL INPUT VOLTAGE.

³⁰ NOMINAL INPUT VOLTAGE, FULL LOAD.

³¹ FOR 3 SECONDS.

● **SELECTION GUIDE(12)**
4:1 5W OUTPUT 3000VDC ISOLATION

MODEL NUMBER	INPUT VOLTAGE (VDC)	OUTPUT VOLTAGE (VDC)	OUTPUT CURRENT (mA)	INPUT ³²		EFF (%) ³³	ISOLATION (VDC) ³⁴
				CURRENT(mA)			
				FULL LOAD	NO LOAD		
CWS-1203.3A5TM-3K	9-36	3.3	1200	470	40	70	3000
CWS-1205A5TM-3K	9-36	5	1000	550	40	76	3000
CWS-1209A5TM-3K	9-36	9	556	540	40	77	3000
CWS-1212A5TM-3K	9-36	12	417	540	20	77	3000
CWS-1215A5TM-3K	9-36	15	333	535	20	78	3000
CWD-1205A5TM-3K	9-36	+/-5	+/-500	560	40	74	3000
CWD-1212A5TM-3K	9-36	+/-12	+/-208	535	40	78	3000
CWD-1215A5TM-3K	9-36	+/-15	+/-167	536	40	78	3000
CWS-2403.3A5TM-3K	18-72	3.3	1200	230	20	72	3000
CWS-2405A5TM-3K	18-72	5	1000	270	20	77	3000
CWS-2409A5TM-3K	18-72	9	556	260	20	80	3000
CWS-2412A5TM-3K	18-72	12	417	265	20	79	3000
CWS-2415A5TM-3K	18-72	15	333	260	20	80	3000
CWD-2405A5TM-3K	18-72	+/-5	+/-500	280	20	74	3000
CWD-2412A5TM-3K	18-72	+/-12	+/-208	270	10	77	3000
CWD-2415A5TM-3K	18-72	+/-15	+/-167	260	10	80	3000

Note: Other input to output voltages may be available. Please contact factory.

ORDERING INFORMATION:

FOR EXAMPLE: CWS-1205A5TM-3K (A PACKAGE 5W SINGLE OUTPUT)
CWD-2405A5TM-3K(A PACKAGE 5W DUAL OUTPUT)

³² NOMINAL INPUT VOLTAGE.

³³ NOMINAL INPUT VOLTAGE, FULL LOAD.

³⁴ FOR 3 SECONDS.

● **SELECTION GUIDE(13)**
2:1 3W OUTPUT(SMD PACKAGE)

MODEL NUMBER	INPUT VOLTAGE (VDC)	OUTPUT VOLTAGE (VDC)	OUTPUT CURRENT (mA)	INPUT ³⁵		EFF (%) ³⁶	ISOLATION (VDC)
				CURRENT(mA)			
				FULL LOAD	NO LOAD		
CWS-1205(ABC)3MS	9-18	5	600	313	18	80	1500
CWS-1212(ABC)3MS	9-18	12	250	301	35	83	1500
CWS-1215(ABC)3MS	9-18	15	200	298	18	84	1500
CWD-1205(ABC)3MS	9-18	+/-5	+/-300	313	18	80	1500
CWD-1212(ABC)3MS	9-18	+/-12	+/-125	301	30	83	1500
CWD-1215(ABC)3MS	9-18	+/-15	+/-100	298	32	84	1500
CWS-2405(ABC)3MS	18-36	5	600	154	10	81	1500
CWS-2412(ABC)3MS	18-36	12	250	149	10	84	1500
CWS-2415(ABC)3MS	18-36	15	200	147	10	85	1500
CWD-2405(ABC)3MS	18-36	+/-5	+/-300	154	10	81	1500
CWD-2412(ABC)3MS	18-36	+/-12	+/-125	149	15	84	1500
CWD-2415(ABC)3MS	18-36	+/-15	+/-100	149	15	84	1500
CWS-4805(ABC)3MS	36-72	5	600	75	5	83	1500
CWS-4812(ABC)3MS	36-72	12	250	74	5	85	1500
CWS-4815(ABC)3MS	36-72	15	200	74	5	85	1500
CWD-4805(ABC)3MS	36-72	+/-5	+/-300	75	5	83	1500
CWD-4812(ABC)3MS	36-72	+/-12	+/-125	74	5	85	1500
CWD-4815(ABC)3MS	36-72	+/-15	+/-100	74	5	85	1500

Note: Other input to output voltages may be available. Please contact factory.

ORDERING INFORMATION:

FOR EXAMPLE: CWS-1205A3MS (SMD A PACKAGE 3W SINGLE OUTPUT)
CWD-2405B3MS (SMD B PACKAGE 3W DUAL OUTPUT)

³⁵ NOMINAL INPUT VOLTAGE.

³⁶ NOMINAL INPUT VOLTAGE, FULL LOAD.

● **SELECTION GUIDE(14)**
2:1 5W OUTPUT(SMD PACKAGE)

MODEL NUMBER	INPUT VOLTAGE (VDC)	OUTPUT VOLTAGE (VDC)	OUTPUT CURRENT (mA)	INPUT ³⁷		EFF (%) ³⁸	ISOLATION (VDC)
				CURRENT(mA)			
				FULL LOAD	NO LOAD		
CWS-1205(ABC)5MS	9-18	5	1000	521	18	80	1500
CWS-1212(ABC)5MS	9-18	12	470	566	18	83	1500
CWS-1215(ABC)5MS	9-18	15	400	595	18	84	1500
CWD-1205(ABC)5MS	9-18	+/-5	+/-500	521	18	80	1500
CWD-1212(ABC)5MS	9-18	+/-12	+/-230	554	30	83	1500
CWD-1215(ABC)5MS	9-18	+/-15	+/-190	579	32	82	1500
CWS-2405(ABC)5MS	18-36	5	1000	257	10	81	1500
CWS-2412(ABC)5MS	18-36	12	470	283	10	83	1500
CWS-2415(ABC)5MS	18-36	15	400	294	10	85	1500
CWD-2405(ABC)5MS	18-36	+/-5	+/-500	257	10	81	1500
CWD-2412(ABC)5MS	18-36	+/-12	+/-230	274	15	84	1500
CWD-2415(ABC)5MS	18-36	+/-15	+/-190	283	15	84	1500
CWS-4805(ABC)5MS	36-72	5	1000	127	5	82	1500
CWS-4812(ABC)5MS	36-72	12	470	138	5	85	1500
CWS-4815(ABC)5MS	36-72	15	400	147	5	85	1500
CWD-4805(ABC)5MS	36-72	+/-5	+/-500	127	5	82	1500
CWD-4812(ABC)5MS	36-72	+/-12	+/-230	135	5	85	1500
CWD-4815(ABC)5MS	36-72	+/-15	+/-190	140	5	85	1500

Note: Other input to output voltages may be available. Please contact factory.

ORDERING INFORMATION:

FOR EXAMPLE: CWS-1205A5MS (SMD A PACKAGE 5W SINGLE OUTPUT)

CWD-2405B5MS (SMD B PACKAGE 5W DUAL OUTPUT)

³⁷ NOMINAL INPUT VOLTAGE.

³⁸ NOMINAL INPUT VOLTAGE, FULL LOAD.

MECHANICAL DIMENSIONS

PACKAGE "A"

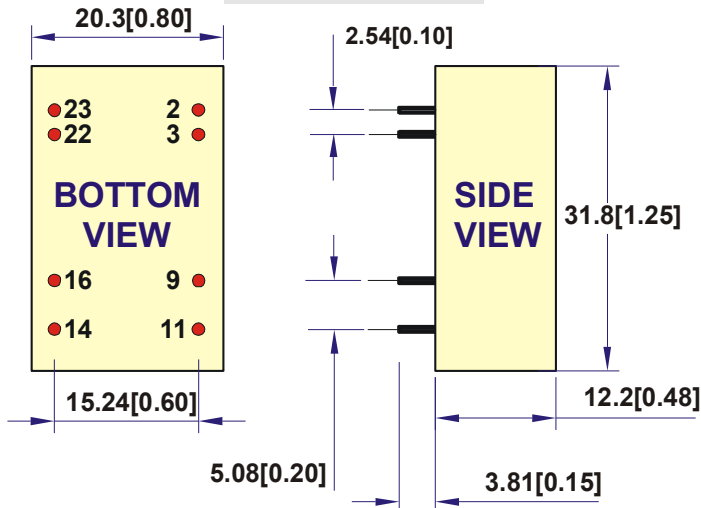

PIN	SINGLE	DUAL
2 & 3	-Vin	-Vin
9	NC	Common
11	NC	-Vout
14	+Vout	+Vout
16	-Vout	Common
22 & 23	+Vin	+Vin

NOTE: Pin Size is Tolerance $0.6\Phi \pm 0.05\text{mm}$

All Dimensions In mm(Inches)

Tolerance .X or .XX = $\pm 0.5\text{mm}$

All dimensions are in mm[inches]

PACKAGE "B"

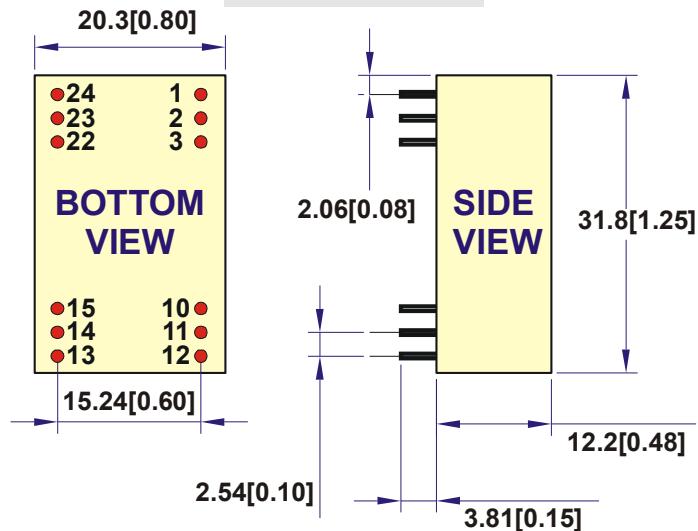

PIN	SINGLE	DUAL
1 & 24	+Vin	+Vin
2 & 23	NP	-Vout
3 & 22	NP	Common
10 & 15	-Vout	Common
11 & 14	+Vout	+Vout
12 & 13	-Vin	-Vin

NOTE: Pin Size is Tolerance $0.6\Phi \pm 0.05\text{mm}$

All Dimensions In mm(Inches)

Tolerance .X or .XX = $\pm 0.5\text{mm}$

All dimensions are in mm[inches]

PACKAGE "C"

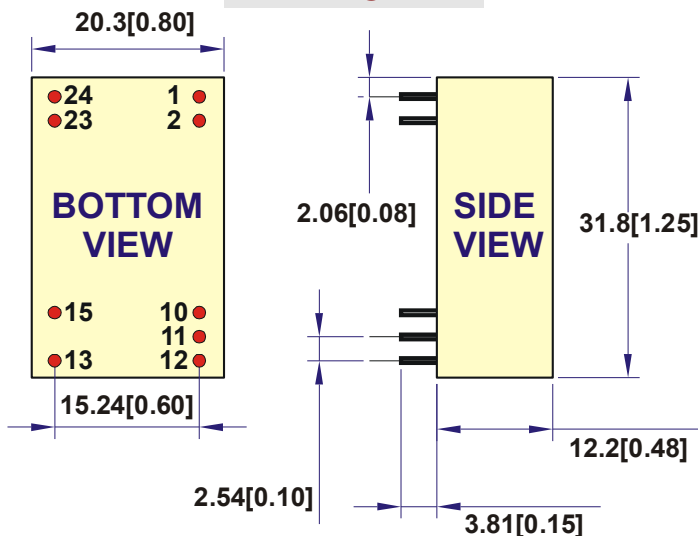

PIN	SINGLE	DUAL
1 & 2	+Vin	+Vin
10 & 11	NC	Common
12	-Vout	NC
13	+Vout	-Vout
15	NC	+Vout
23 & 24	-Vin	-Vin

NOTE: Pin Size is Tolerance $0.6\Phi \pm 0.05\text{mm}$

All Dimensions In mm(Inches)

Tolerance .X or .XX = $\pm 0.5\text{mm}$

All dimensions are in mm[inches]

PACKAGE "D"

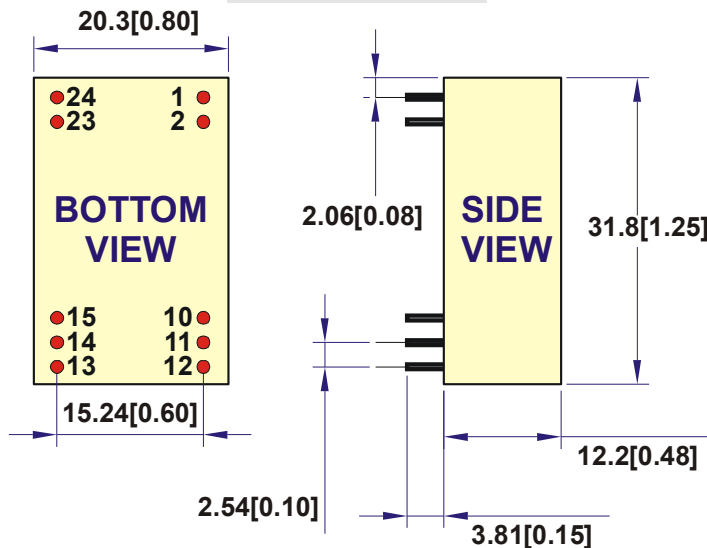

PIN	SINGLE
1 & 24	+ Vin
2 & 23	-Vin
10 & 15	-Vout
11 & 14	NC
12 & 13	+Vout

NOTE: Pin Size is Tolerance $0.6\Phi \pm 0.05\text{mm}$

All Dimensions In mm(Inches)

Tolerance .X or .XX = $\pm 0.5\text{mm}$

All dimensions are in mm[inches]

PACKAGE "E"

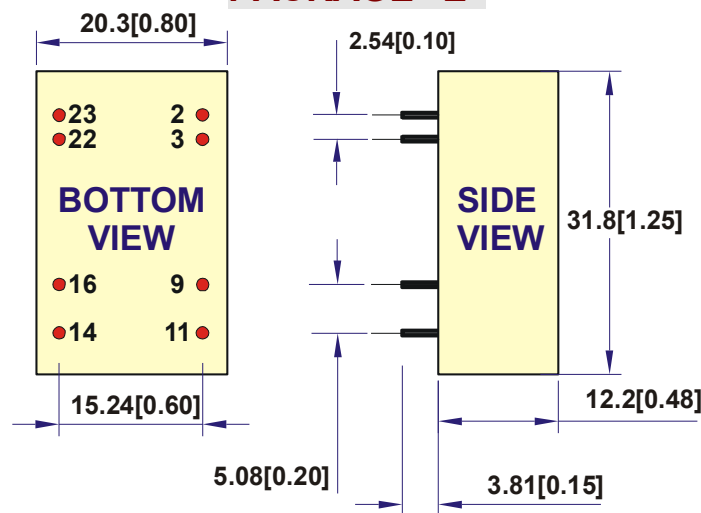

PIN	SEPARATE
2 & 3	- Vin
9	-Vout2
11	+Vout2
14	+Vout1
16	-Vout1
22 & 23	+Vin

NOTE: Pin Size is Tolerance $0.6\Phi \pm 0.05\text{mm}$

All Dimensions In mm(Inches)

Tolerance .X or .XX = $\pm 0.5\text{mm}$

All dimensions are in mm[inches]

PACKAGE "F"

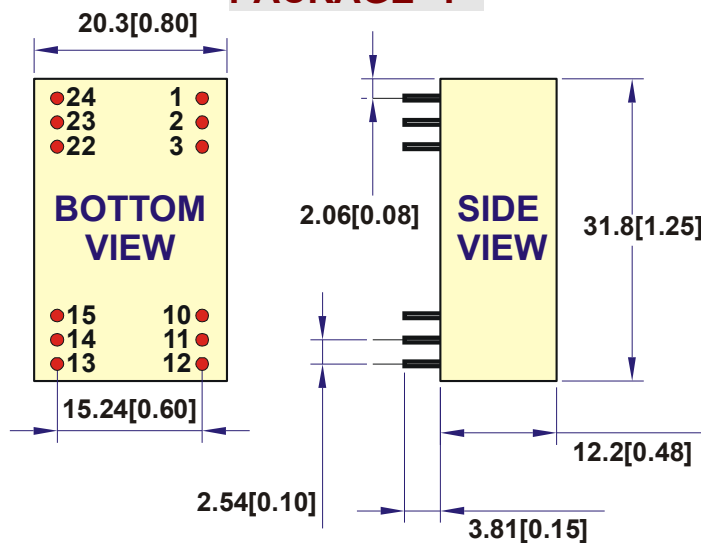

PIN	SEPARATE
1 & 24	+ Vin
2 & 23	-Vout2
3 & 22	+Vout2
10 & 15	-Vout1
11 & 14	+Vout1
12 & 13	-Vin

NOTE: Pin Size is Tolerance $0.6\Phi \pm 0.05\text{mm}$

All Dimensions In mm(Inches)

Tolerance .X or .XX = $\pm 0.5\text{mm}$

All dimensions are in mm[inches]

PACKAGE "P"

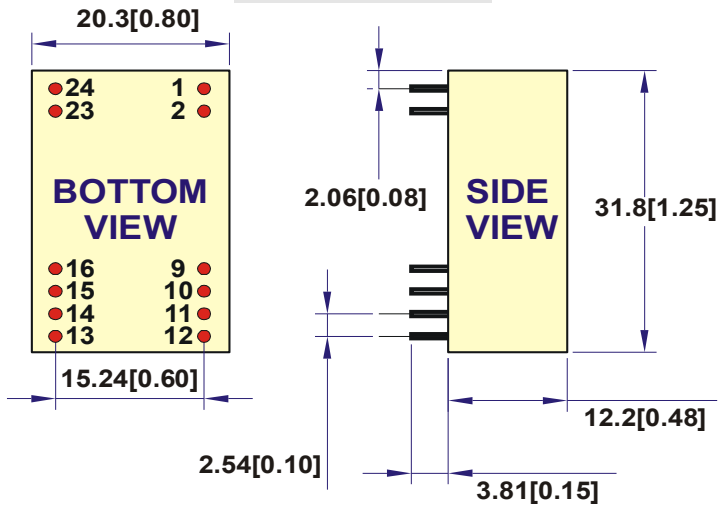

PIN	SINGLE
1 & 2	+Vin
23 & 24	-Vin
9 & 10	-Vout
11 & 12	+Vout
13 & 14	NC
15 & 16	NC

NOTE: Pin Size is Tolerance $0.6\Phi \pm 0.05\text{mm}$

All Dimensions In mm(Inches)

Tolerance .X or .XX = $\pm 0.5\text{mm}$

All dimensions are in mm[inches]

PACKAGE "T"

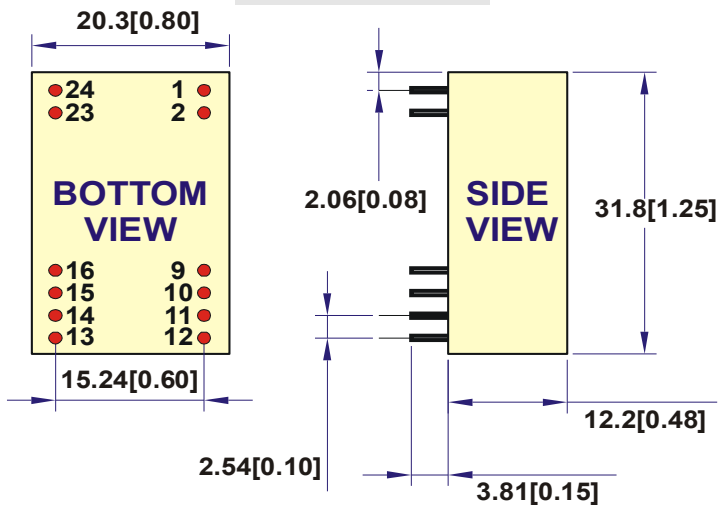

PIN	TRIPLE
1 & 2	-Vin
23 & 24	+Vin
9 & 16	-Vout(Out3)
10 & 15	Common
11 & 14	+5V/300mA(Out1)
12 & 13	+Vout(Out2)

NOTE: Pin Size is Tolerance $0.6\Phi \pm 0.05\text{mm}$

All Dimensions In mm(Inches)

Tolerance .X or .XX = $\pm 0.5\text{mm}$

All dimensions are in mm[inches]

SMD PACKAGE

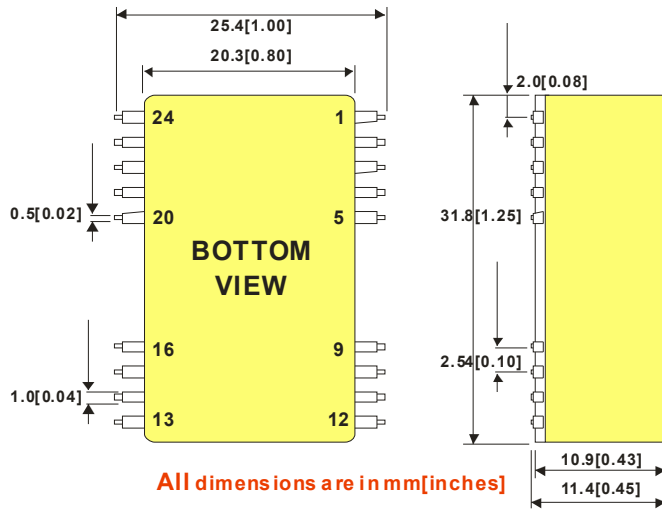

SMD PACKAGE "A"

PIN	SINGLE	DUAL
1	ON/OFF	ON/OFF
2 & 3	-Vin	-Vin
4 & 5	NC	NC
9	NC	COM
10 & 12	NC	NC
11	NC	-VOUT
13 & 15	NC	NC
14	+VOUT	+VOUT
16	-VOUT	COM
20 & 21	NC	NC
22 & 23	+VIN	+VIN
24	NC	NC

SMD PACKAGE "B"

PIN	SINGLE	DUAL
1 & 24	+Vin	+Vin
2 & 23	NC	-Vout
3 & 22	NC	Common
4 & 21	NC	NC
5 & 20	NC	NC
9 & 16	NC	NC
10 & 15	-Vout	Common
11 & 14	+Vout	+Vout
12 & 13	-Vin	-Vin

SMD PACKAGE "C"

PIN	SINGLE	DUAL
1 & 2	+Vin	+Vin
3 & 4	NC	NC
5 & 9	NC	NC
10 & 11	NC	Common
12	-Vout	NC
13	+Vout	-Vout
14 & 16	NC	NC
15	NC	+Vout
20 & 21	NC	NC
22	NC	NC
23 & 24	-Vin	-Vin

NOTE: All Dimensions In mm(Inches)

Pin Size is Tolerance $0.5 \pm 0.05\text{mm}$

Tolerance .X or .XX= $\pm 0.5\text{mm}$

● RECOMMENDED FOOTPRINT DETAILS

PACKAGE "A"

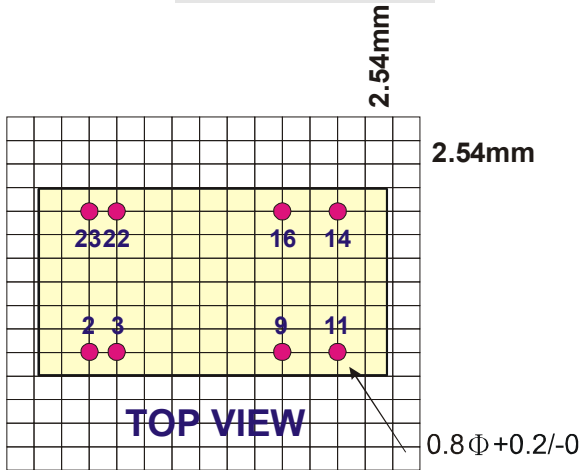

PACKAGE "B"

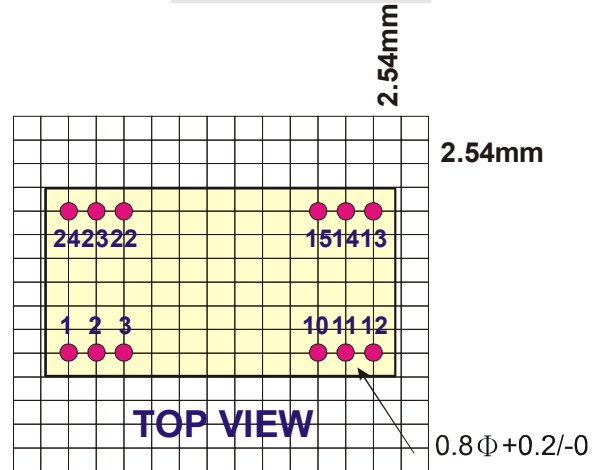

PACKAGE "C"

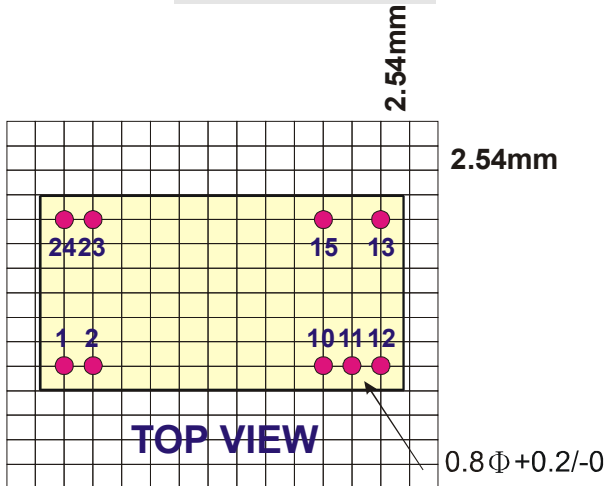

PACKAGE "D"

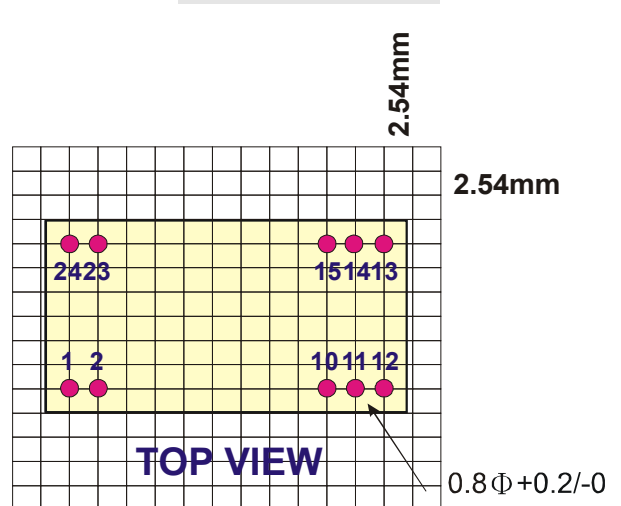

PACKAGE "E"

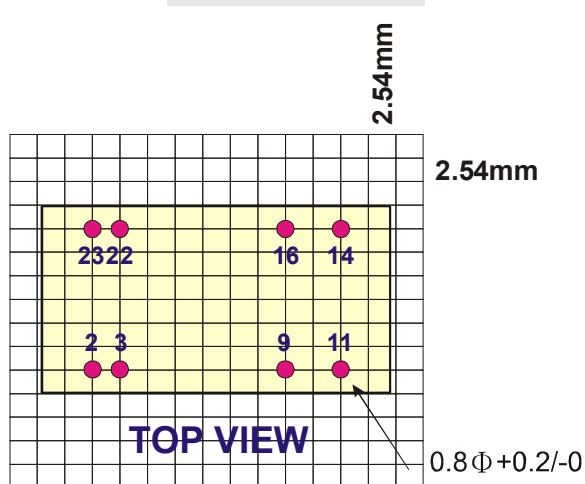

PACKAGE "F"

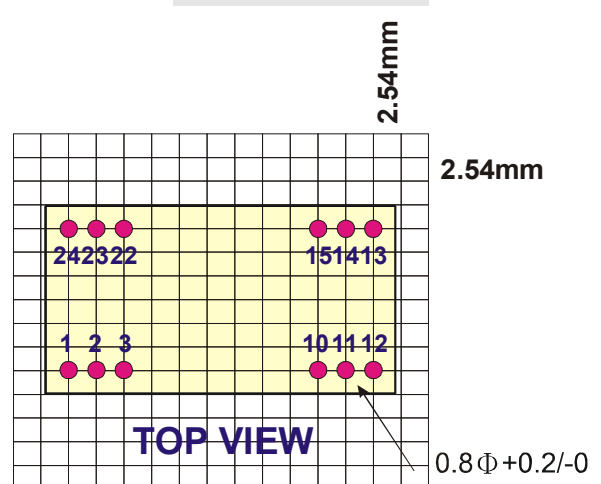

PACKAGE "P"

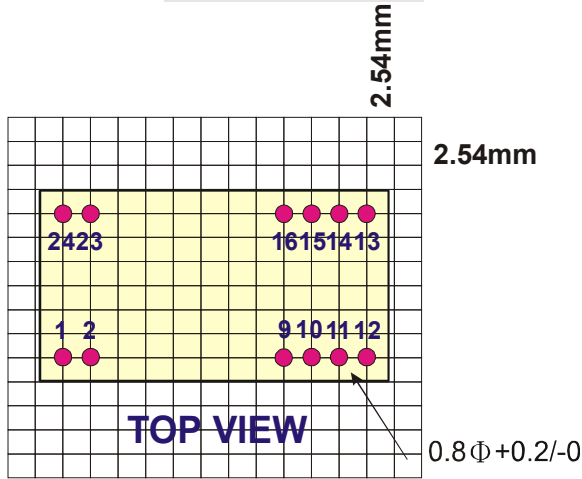

PACKAGE "T"

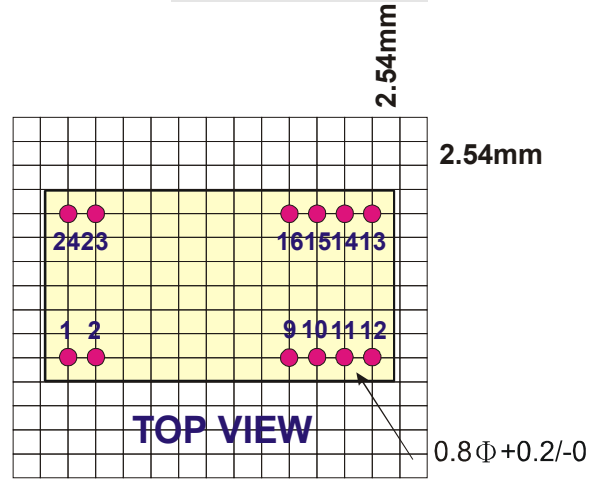

PACKAGE "S" [SMD]

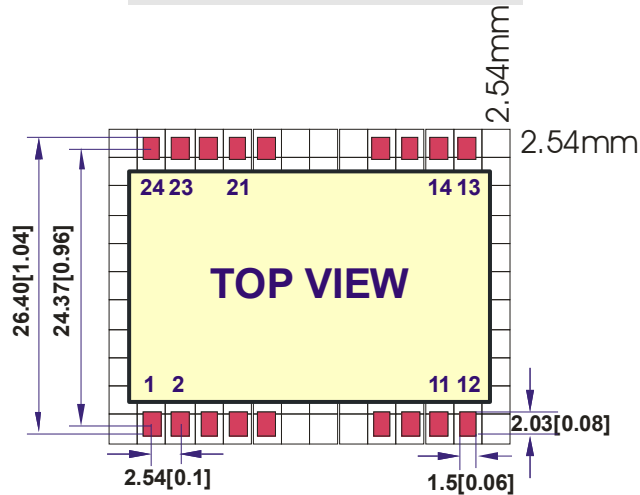

● RECOMMENDED REFLOW SOLDERING PROFILE

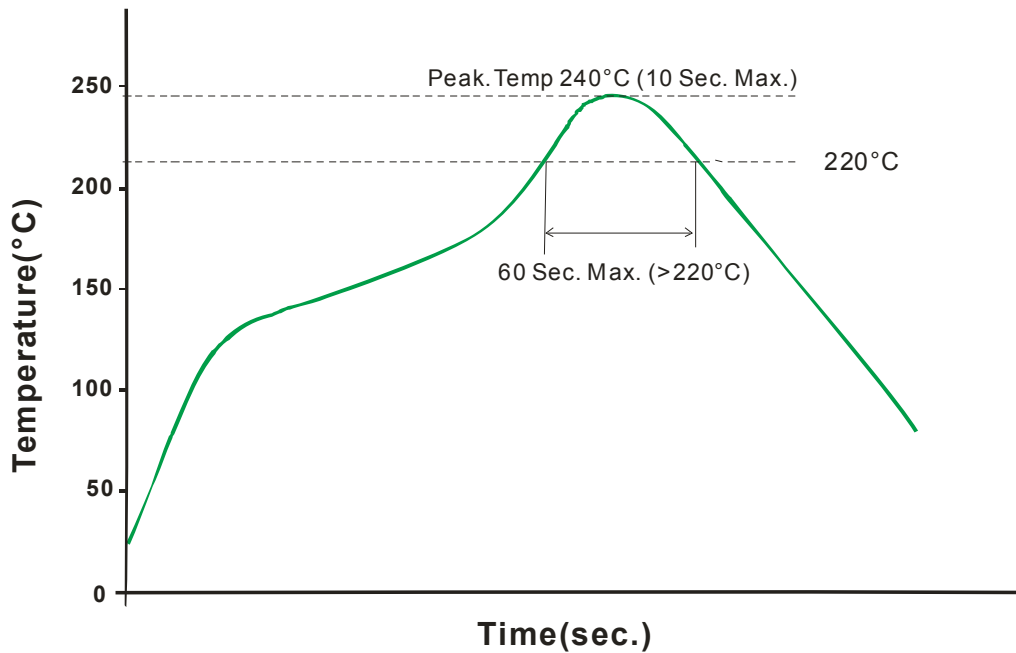

● SIMPLIFIED SCHEMATIC

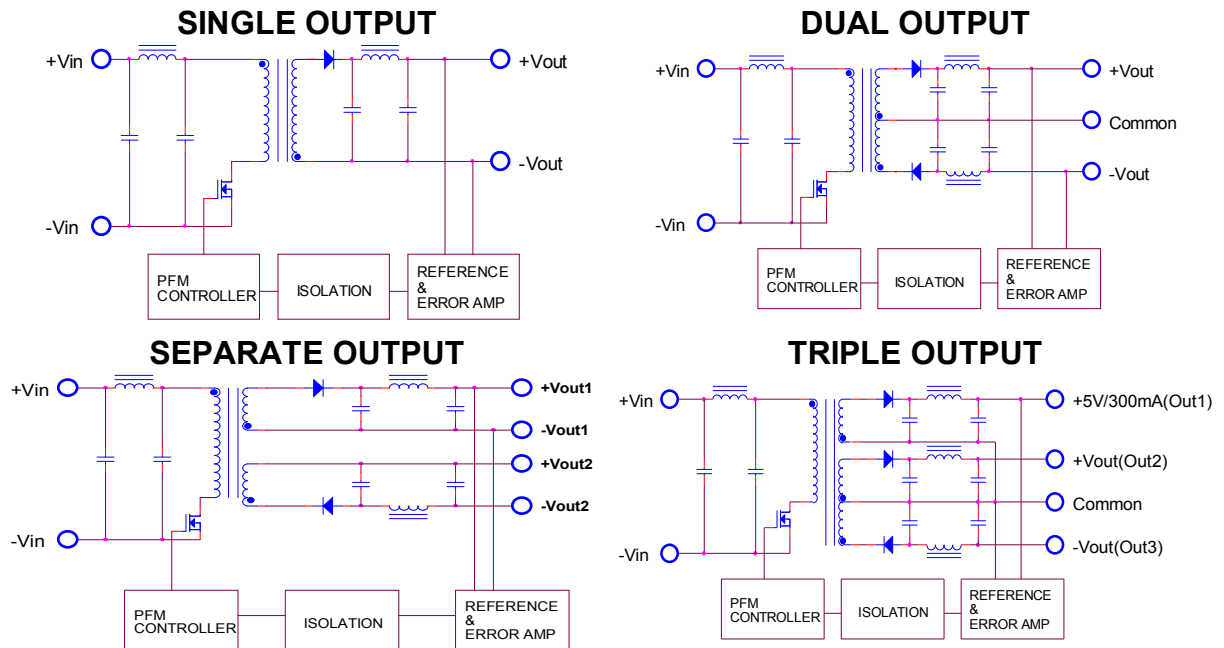

● TYPICAL APPLICATIONS

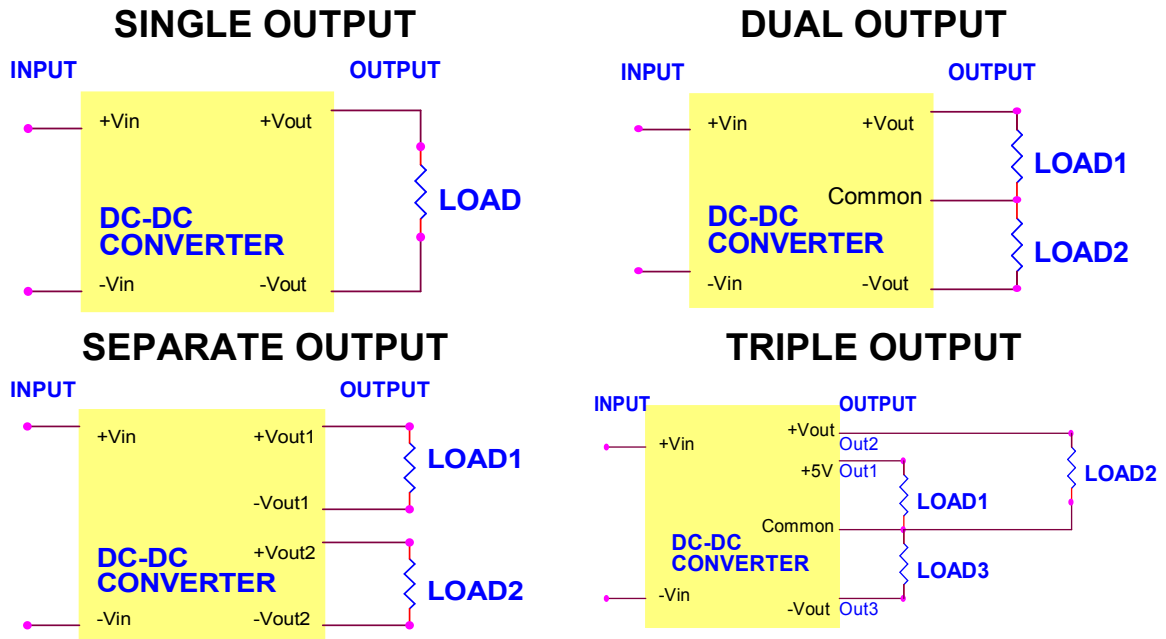

● TYPICAL PERFORMANCE CURVES

Specifications typical at $T_a=25^\circ\text{C}$, nominal input voltage, rated output current unless otherwise specified.

OUTPUT LOAD VS EFFICIENCY

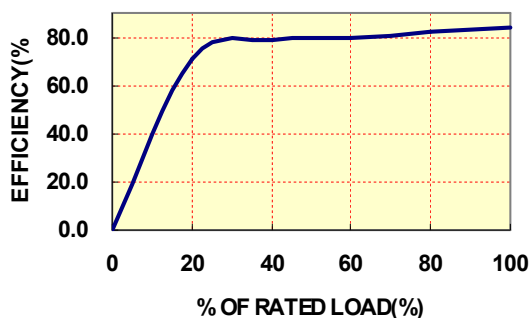

TEMPERATURE DERATING

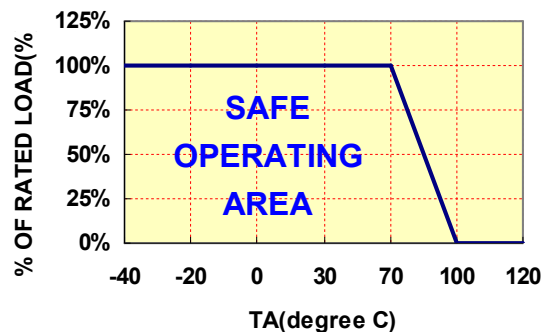

● Table1 (Remote On/Off Control)

Remote On/Off Control		
Parameter	Min	Max
Supply On	Under 1 VDC or Open Circuit	
Supply Off	4VDC	
Standby Input Current		0.2mA
Control Input Current(On)		-0.5mA
Control Input Current(Off)		5mA
Control Common	Referenced to -Vin	

● INPUT FUSE SELECTION GUIDE

4.5-6.0V or 4.5-9V INPUT VOLTAGE(VDC)	9-18V or 9-36V INPUT VOLTAGE(VDC)	18-36V or 18-72V INPUT VOLTAGE(VDC)	36-72V INPUT VOLTAGE(VDC)
3000mA Slow-Blow Type	1500mA Slow-Blow Type	800mA Slow-Blow Type	400mA Slow-Blow Type

Note: Certain applications may require the installation of external fuse in front of the input.

CW SERIES APPLICATION NOTES:

EXTERNAL CAPACITANCE REQUIREMENTS:

No external capacitance is required for operation of the CW series.

To meet the reflected ripple requirements of the converter, an input impedance of less than 0.5 ohm from DC to 100KHz is required.

External output capacitance is not required for operation, however it is recommended that 10uF tantalum and 0.1uF ceramic capacitance be selected for reduced system noise.

Additional output capacitance may be added for increased filtering, but should not exceed 1000uF.

We Can Offer EMC-Filter According To EN55011/22 Class B.

Negative Outputs:

A negative output voltage may be obtained by connecting the +OUT to circuit ground and connecting -OUT as the negative output.

FOR MORE INFORMATION CALL:

Danube Enterprise Co., Ltd.

Tel: 886-7-3755165

Fax: 886-7-3755330

E-mail: danube@ms10.hinet.net

Home Page

<http://www.danube.com.tw>
