

CQW-6K SERIES

3-5W WIDE INPUT RANGE

DANUBE

FEATURES

- 3-5W DIL PACKAGE
- 4.5-9V,9-18V,18-36V,36-72V WIDE INPUT RANGE
- 100% BURN-IN
- HIGH EFFICIENCY
- UL 94-V0 PACKAGE MATERIAL
- CUSTOM SOLUTIONS AVAILABLE
- RoHS COMPLIANT
- 3 YEARS WARRANTY



OUTPUT SPECIFICATIONS

Voltage Set-point Accuracy	+/-2% max.
Temperature Coefficient	+/-0.05%/°C
Ripple & Noise(20MHz BW) ¹	100mVp-p max.
Line Regulation ²	+/-1% max.
Load Regulation ³	+/-0.5% max.
Minimum Load	20% of Full Load
Short Circuit Protection	Continuous
Short Circuit Restart	Automatic
Over Load Protection	110%~180%
Transient Response ⁵	200uS max.

INPUT SPECIFICATIONS

Input Voltage Range	2:1 Input Range
Input Filter	Pi Network
Protection	Fuse Recommended
Remote ON/OFF Control	Table 1

GENERAL SPECIFICATIONS

Efficiency	70% min.
Isolation Voltage ⁴	6000VDC min.
Isolation Resistance	10 ⁹ ohms min.
Isolation Capacitance	40pF max.
Switching Frequency	50KHz min.
MTBF ⁶	>900,000 Hours
Weight	17.5g Typ.
Case Material	Non-Conductive Plastic
Case Size	31.8mm*20.3mm*10.2mm
Potting Material	Epoxy(UL 94V-0)
Conducted Emissions	EN55022 Class A
Radiated Emissions	EN55022 Class B
Safety Standard:	UL-60950-1
(designed to meet)	

ENVIRONMENTAL SPECIFICATIONS

Operating Temperature	-40 °C to +85 °C
Case Temperature	+95 °C max.
Storage Temperature	-55 °C to +125 °C
Humidity	95% max.
Cooling	Free-Air Convection

ALL SPECIFICATIONS TYPICAL AT NOMINAL LINE, FULL LOAD, AND 25 °C UNLESS OTHERWISE NOTED.

¹ Measured with 1uF ceramic capacitor connect to the output pins.

² High Line to Low Line.

³ Load Regulation is for output load current change from 20% to 100%.

⁴ 6000VDC for 3 seconds, 2000VDC for 120 seconds.

⁵ 25% Step Load Change.

⁶ MIL-HDBK-217F @25 °C, Ground Benign.

DANUBE

<http://www.danube.com.tw>

● SELECTION GUIDE(1) 2:1 3W OUTPUT

MODEL NUMBER	INPUT VOLTAGE (VDC)	OUTPUT VOLTAGE (VDC)	OUTPUT CURRENT (mA)	INPUT ⁷ CURRENT(mA)		EFF (%) ⁸	Isolation (VDC)
				FULL LOAD	NO LOAD		
CQWS-0503.3(AC)3-6K	4.5-9	3.3	900	855	40	70	6000
CQWS-0505(AC)3-6K	4.5-9	5	500	670	40	75	6000
CQWS-0512(AC)3-6K	4.5-9	12	250	789	40	76	6000
CQWS-0515(AC)3-6K	4.5-9	15	200	789	40	76	6000
CQWD-0505(AC)3-6K	4.5-9	+/-5	+/-300	855	40	70	6000
CQWD-0509(AC)3-6K	4.5-9	+/-9	+/-167	835	40	72	6000
CQWD-0512(AC)3-6K	4.5-9	+/-12	+/-125	810	40	74	6000
CQWD-0515(AC)3-6K	4.5-9	+/-15	+/-100	800	50	75	6000
CQWS-1205(AC)3-6K	9-18	5	600	321	22	78	6000
CQWS-1209(AC)3-6K	9-18	9	330	316	18	79	6000
CQWS-1212(AC)3-6K	9-18	12	250	313	30	80	6000
CQWS-1215(AC)3-6K	9-18	15	200	313	32	80	6000
CQWD-1205(AC)3-6K	9-18	+/-5	+/-300	338	18	74	6000
CQWD-1212(AC)3-6K	9-18	+/-12	+/-125	316	30	79	6000
CQWD-1215(AC)3-6K	9-18	+/-15	+/-100	316	32	79	6000
CQWS-2403.3(AC)3-6K	18-36	3.3	910	163	10	76	6000
CQWS-2405(AC)3-6K	18-36	5	600	167	10	75	6000
CQWS-2409(AC)3-6K	18-36	9	330	158	10	79	6000
CQWS-2412(AC)3-6K	18-36	12	250	156	10	80	6000
CQWS-2415(AC)3-6K	18-36	15	200	156	10	80	6000
CQWS-2424(AC)3-6K	18-36	24	125	156	10	80	6000
CQWD-2405(AC)3-6K	18-36	+/-5	+/-300	167	10	75	6000
CQWD-2412(AC)3-6K	18-36	+/-12	+/-125	156	15	80	6000
CQWD-2415(AC)3-6K	18-36	+/-15	+/-100	156	15	80	6000
CQWS-4805(AC)3-6K	36-72	5	600	82	5	76	6000
CQWS-4809(AC)3-6K	36-72	9	330	79	5	79	6000
CQWS-4812(AC)3-6K	36-72	12	250	80	5	78	6000
CQWS-4815(AC)3-6K	36-72	15	200	76	5	82	6000
CQWD-4805(AC)3-6K	36-72	+/-5	+/-300	82	5	76	6000
CQWD-4812(AC)3-6K	36-72	+/-12	+/-125	80	5	78	6000
CQWD-4815(AC)3-6K	36-72	+/-15	+/-100	79	5	79	6000

Note: Other input to output voltages may be available. Please contact factory.

⁷ NOMINAL INPUT VOLTAGE.

⁸ NOMINAL INPUT VOLTAGE, FULL LOAD.

● SELECTION GUIDE(2) 2:1 4W-6W OUTPUT

MODEL NUMBER	INPUT VOLTAGE (VDC)	OUTPUT VOLTAGE (VDC)	OUTPUT CURRENT (mA)	INPUT ⁹ CURRENT(mA)		EFF (%) ¹⁰	Isolation (VDC)
				FULL LOAD	NO LOAD		
CQWS-0505(AC)5-6K	4.5-9	5	800	1080	40	74	6000
CQWS-0512(AC)5-6K	4.5-9	12	333	1060	40	75	6000
CQWS-0515(AC)5-6K	4.5-9	15	267	1060	40	75	6000
CQWD-0505(AC)5-6K	4.5-9	+/-5	+/-400	1125	40	71	6000
CQWD-0512(AC)5-6K	4.5-9	+/-12	+/-167	1073	120	75	6000
CQWD-0515(AC)5-6K	4.5-9	+/-15	+/-133	1060	100	75	6000
CQWS-1205(AC)5-6K	9-18	5	1000	527	40	79	6000
CQWS-1209(AC)5-6K	9-18	9	556	520	40	80	6000
CQWS-1212(AC)5-6K	9-18	12	470	587	40	80	6000
CQWS-1215(AC)5-6K	9-18	15	400	617	41	81	6000
CQWD-1205(AC)5-6K	9-18	+/-5	+/-500	556	40	75	6000
CQWD-1209(AC)5-6K	9-18	+/-9	+/-278	556	40	75	6000
CQWD-1212(AC)5-6K	9-18	+/-12	+/-208	527	40	79	6000
CQWD-1215(AC)5-6K	9-18	+/-15	+/-167	515	41	81	6000
CQWS-2405(AC)5-6K	18-36	5	1000	270	20	77	6000
CQWS-2409(AC)5-6K	18-36	9	556	257	20	81	6000
CQWS-2412(AC)5-6K	18-36	12	470	292	22	80	6000
CQWS-2415(AC)5-6K	18-36	15	400	301	21	83	6000
CQWS-2424(AC)5-6K	18-36	24	208	260	20	80	6000
CQWD-2405(AC)5-6K	18-36	+/-5	+/-500	270	20	77	6000
CQWD-2412(AC)5-6K	18-36	+/-12	+/-208	254	20	82	6000
CQWD-2415(AC)5-6K	18-36	+/-15	+/-167	252	21	83	6000
CQWS-4805(AC)5-6K	36-72	5	1000	132	10	79	6000
CQWS-4809(AC)5-6K	36-72	9	556	130	9	80	6000
CQWS-4812(AC)5-6K	36-72	12	470	146	9	80	6000
CQWS-4815(AC)5-6K	36-72	15	400	154	10	81	6000
CQWD-4805(AC)5-6K	36-72	+/-5	+/-500	135	10	77	6000
CQWD-4812(AC)5-6K	36-72	+/-12	+/-208	130	12	80	6000
CQWD-4815(AC)5-6K	36-72	+/-15	+/-167	129	10	81	6000

Note: Other input to output voltages may be available. Please contact factory.

⁹ NOMINAL INPUT VOLTAGE.

¹⁰ NOMINAL INPUT VOLTAGE, FULL LOAD.

MECHANICAL DIMENSIONS & RECOMMENDED FOOTPRINT DETAILS

PACKAGE "A"

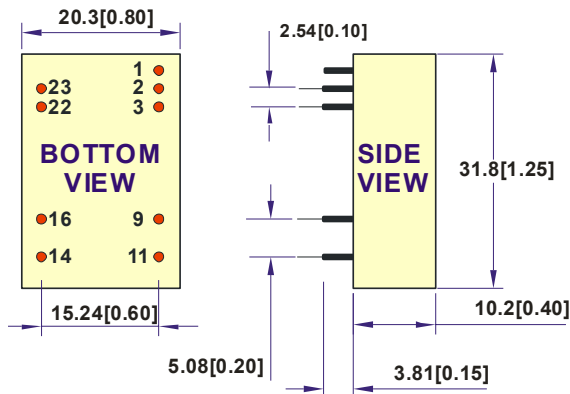

All dimensions are in mm[inches]

PIN	SINGLE	DUAL
1	Remote On/Off	Remote On/Off
2 & 3	-Vin	-Vin
9	NC	Common
11	NC	-Vout
14	+Vout	+Vout
16	-Vout	Common
22 & 23	+Vin	+Vin

NOTE: Pin Size is Tolerance $0.6\Phi \pm 0.05\text{mm}$

All Dimensions In mm(Inches)

Tolerance .X or .XX = $\pm 0.5\text{mm}$

PACKAGE "C"

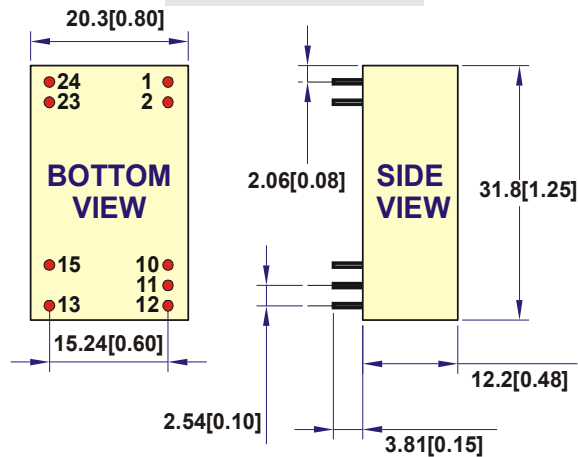

All dimensions are in mm[inches]

PIN	SINGLE	DUAL
1 & 2	+Vin	+Vin
10 & 11	NC	Common
12	-Vout	NC
13	+Vout	-Vout
15	NC	+Vout
23 & 24	-Vin	-Vin

NOTE: Pin Size is Tolerance $0.6\Phi \pm 0.05\text{mm}$

All Dimensions In mm(Inches)

Tolerance .X or .XX = $\pm 0.5\text{mm}$

RECOMMENDED FOOTPRINT DETAILS

PACKAGE "A"

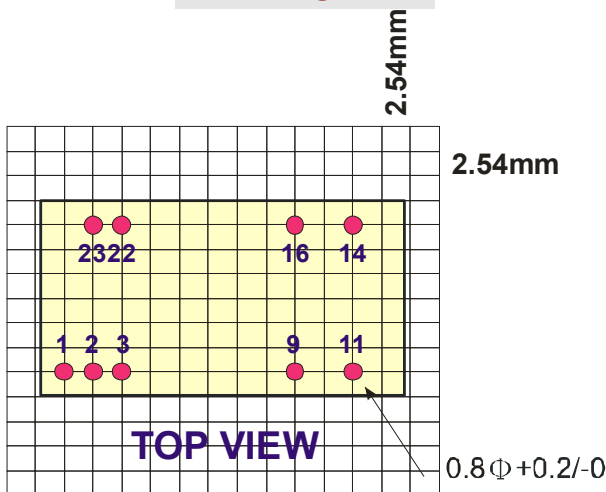

PACKAGE "C"

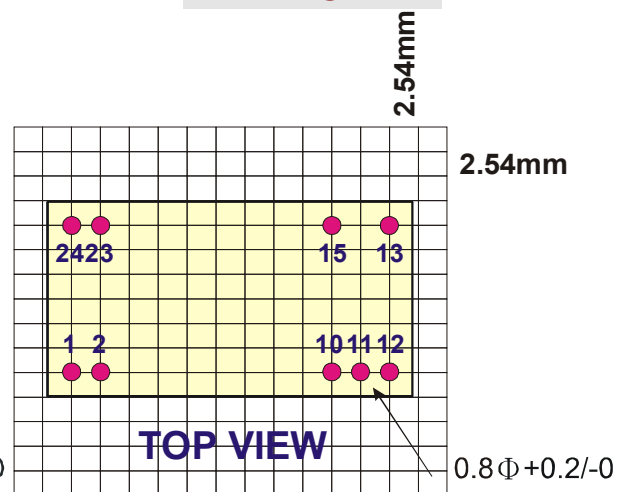

● Table1 (Remote On/Off Control)

Remote On/Off Control		
Parameter	Min	Max
Supply On	Under 1 VDC or Open Circuit	
Supply Off	4VDC	
Standby Input Current		0.2mA
Control Input Current(On)		-0.5mA
Control Input Current(Off)		5mA
Control Common	Referenced to -Vin (pin 2&3)	

● SIMPLIFIED SCHEMATIC

SINGLE OUTPUT

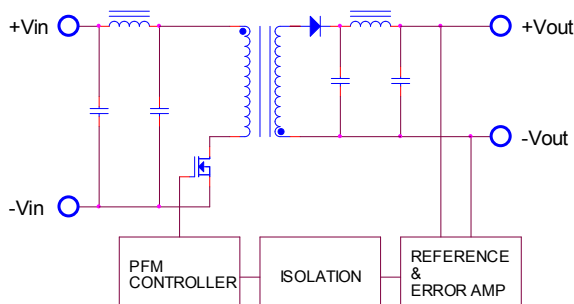

DUAL OUTPUT

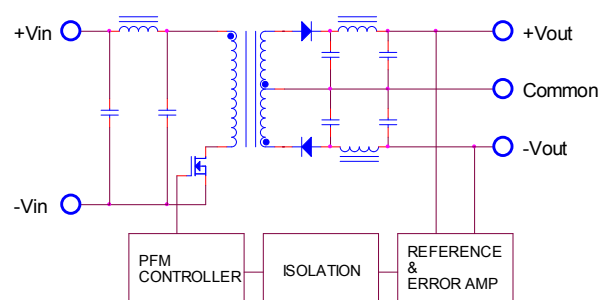

● TYPICAL APPLICATIONS

SINGLE OUTPUT

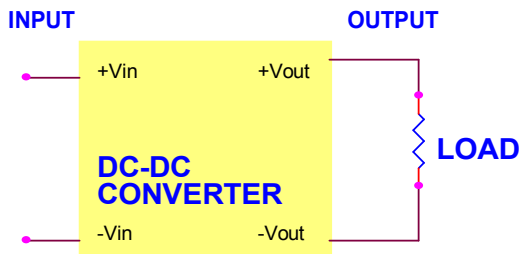

DUAL OUTPUT

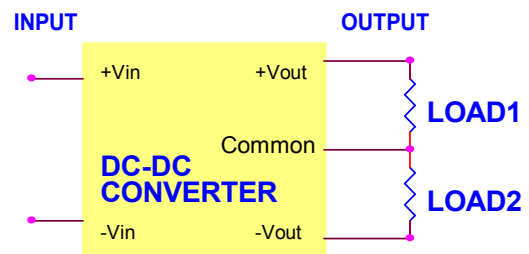

● TYPICAL PERFORMANCE CURVES

Specifications typical at $T_a=25^\circ\text{C}$, nominal input voltage, rated output current unless otherwise specified.

OUTPUT LOAD VS EFFICIENCY

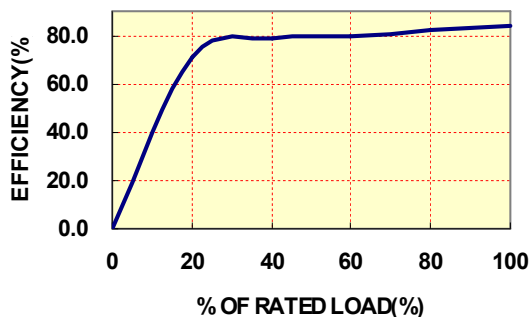

TEMPERATURE DERATING

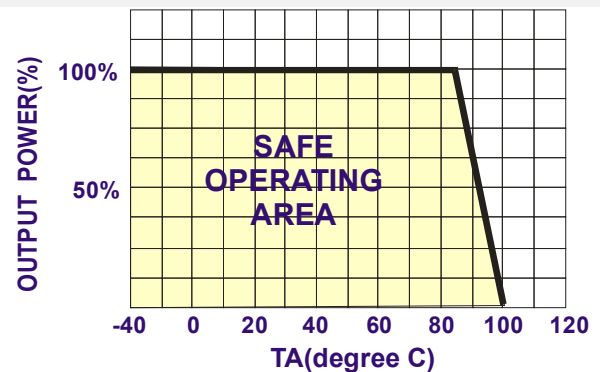

● INPUT FUSE SELECTION GUIDE

4.5-9V INPUT VOLTAGE(VDC)	9-18V INPUT VOLTAGE(VDC)	18-36V INPUT VOLTAGE(VDC)	36-72V INPUT VOLTAGE(VDC)
2500mA Slow-Blow Type	1500mA Slow-Blow Type	600mA Slow-Blow Type	300mA Slow-Blow Type

The diagram shows a yellow rectangular DC-DC converter. On the left side, there are two input terminals labeled '+Vin' (top) and '-Vin' (bottom). On the right side, there are two output terminals labeled '+Vout' (top) and '-Vout' (bottom). A fuse is connected between the input and the +Vin terminal. The word 'DC-DC CONVERTER' is written in blue on the yellow box. The word 'INPUT' is written above the input terminals, and 'OUTPUT' is written above the output terminals.

Note: Certain applications may require the installation of external fuse in front of the input.

CQW-6K SERIES APPLICATION NOTES:

EXTERNAL CAPACITANCE REQUIREMENTS:

No external capacitance is required for operation of the CQW-6K series.

To meet the reflected ripple requirements of the converter, an input impedance of less than 0.5 ohm from DC to 100KHz is required.

External output capacitance is not required for operation, however it is recommended that 10uF tantalum and 0.1uF ceramic capacitance be selected for reduced system noise.

Additional output capacitance may be added for increased filtering, but should not exceed 1000uF.

We Can Offer EMC-Filter According To EN55011/22 Class B.

Negative Outputs:

A negative output voltage may be obtained by connecting the +OUT to circuit ground and connecting -OUT as the negative output.

FOR MORE INFORMATION CALL:

Danube Enterprise Co., Ltd.

Tel: 886-7-3755165

Fax: 886-7-3755330

E-mail: danube@ms10.hinet.net

Home Page

<http://www.danube.com.tw>
