

# MD300ERW Series

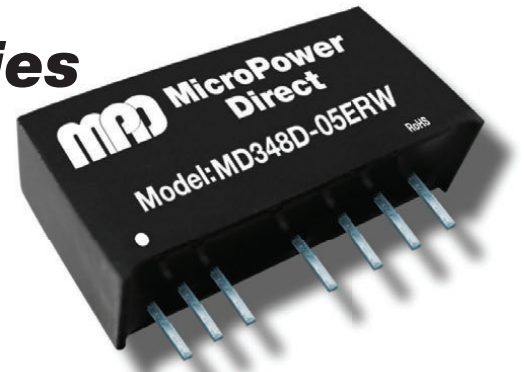

## 2:1 Input, 3W SIP, Single & Dual Output DC/DC Converters

### Key Features:

- 3W Output Power
- 2:1 Input Voltage Range
- Short Circuit Protected
- 1,500 VDC Isolation
- 29 Standard Models
- Miniature SIP Case
- -40°C to +85°C Operation
- Industry Standard Pin-Out
- Low Cost

RoHS



### Electrical Specifications

Specifications typical @ +25°C, nominal input voltage & rated output current, unless otherwise noted. Specifications subject to change without notice.

Input						
Parameter	Conditions	Min.	Typ.	Max.	Units	
Input Voltage Range	5 VDC Input	4.5	5.0	9.0	VDC	
	12 VDC Input	9.0	12.0	18.0		
	24 VDC Input	18.0	24.0	36.0		
	48 VDC Input	36.0	48.0	75.0		
Input Start Voltage	5 VDC Input	3.5	4.0	4.5	VDC	
	12 VDC Input	4.5	8.0	9.0		
	24 VDC Input	11.0	16.0	18.0		
	48 VDC Input	24.0	33.0	36.0		
Input Filter	Capacitor Filter					

Output						
Parameter	Conditions	Min.	Typ.	Max.	Units	
Output Voltage Accuracy, See Note 1	I <sub>OUT</sub> = 5% to 100%	±1.0	±3.0	%		
Output Voltage Balance, See Note 2	Dual Outputs, Balanced Loads	±0.5	±1.0	%		
Line Regulation	V <sub>IN</sub> = Min to Max	±0.2	±0.5	%		
Load Regulation	I <sub>OUT</sub> = 5% to 100%	±0.6	±1.0	%		
Ripple (20 MHz)	See Note 3	30	45	mV P - P		
Noise (20 MHz)	See Note 3	35	75	mV P - P		
Transient Recovery Time, See Note 4	25% Load Step Change	0.5	3.0	mSec		
Transient Response Deviation		±2.5	±5.0	%		
Temperature Coefficient		±0.03	%/°C			
Output Short Circuit	Continuous (Autorecovery)					

General						
Parameter	Conditions	Min.	Typ.	Max.	Units	
Isolation Voltage	60 Seconds	1,500			VDC	
Isolation Resistance	500 VDC	1,000			MΩ	
Isolation Capacitance	100 kHz/0.1V		120		pF	
Switching Frequency			250		kHz	

EMI Characteristics						
Parameter	Standard		Level			
Radiated Emissions	See Note 5	EN 55022	Class B			
Conducted Emissions	See Note 5	EN 55022	Class B			
ESD		EN 61000-4-2	Criteria B; ±4 kV Contact			
RS		EN 61000-4-3	Criteria A; 10V/m			
EFT	See Note 6	EN 61000-4-4	Criteria B; ±2 kV			
	See Note 6	EN 61000-4-4	Criteria B; ±4 kV			
Surge	See Note 7	EN 61000-4-5	Criteria B; ±2 kV			
CS		EN 61000-4-6	Criteria A; 3 Vrms			
Voltage Dips		EN 61000-4-29	Criteria B; 0% - 70%			

Environmental						
Parameter	Conditions	Min.	Typ.	Max.	Units	
Operating Temperature Range	Ambient	-40	+25	+85	°C	
Storage Temperature Range		-55		+125	°C	
Cooling	Free Air Convection					
Humidity	RH, Non-condensing			95	%	

Physical						
Parameter	Conditions					
Case Size	0.866 x 0.374 x 0.472 Inches (22.00 x 9.50 x 12.00 mm)					
Case Material	Non-Conductive Black Plastic (UL94-V0)					
Weight	0.17 Oz (4.9g)					

Reliability Specifications						
Parameter	Conditions	Min.	Typ.	Max.	Units	
MTBF	MIL HDBK 217F, 25°C, Gnd Benign	1.0			MHours	

Absolute Maximum Ratings						
Parameter	Conditions	Min.	Typ.	Max.	Units	
Input Voltage Surge (1 Sec)	5 VDC Input	-0.7		12.0	VDC	
	12 VDC Input	-0.7		25.0		
	24 VDC Input	-0.7		50.0		
	48 VDC Input	-0.7		100.0		
Lead Temperature	1.5 mm From Case for 10 Sec			300	°C	

Caution: Exceeding Absolute Maximum Ratings may damage the module. These are not continuous operating ratings.

### MicroPower Direct

292 Page Street  
Suite D  
Stoughton, MA 02072  
USA

T: (781) 344-8226

F: (781) 344-8481

E: sales@micropowerdirect.com

W: www.micropowerdirect.com



www.micropowerdirect.com

Model Number	Input				Output			Efficiency (% Typ)	Reflected Ripple Current (mA Typ)	Capacitive Load (µF, Max)	Fuse Rating Slow-Blow (mA)
	Voltage (VDC)		Current (mA)		Voltage (VDC)	Current (mA, Max)	Current (mA, Min)				
	Nominal	Range	Full-Load	No-Load							
MD305S-05ERW	5	4.5 - 9.0	685	40	5.0	500	25.0	73	30.0	2,200	1,500
MD305S-09ERW	5	4.5 - 9.0	676	40	9.0	278	14.0	74	30.0	1,000	1,500
MD305S-12ERW	5	4.5 - 9.0	650	40	12.0	208	10.0	77	30.0	630	1,500
MD305S-15ERW	5	4.5 - 9.0	676	40	15.0	167	8.0	74	30.0	470	1,500
MD305D-05ERW	5	4.5 - 9.0	676	40	±5.0	±250	±13.0	74	30.0	1,000	1,500
MD305D-12ERW	5	4.5 - 9.0	650	40	±12.0	±104	±5.0	77	30.0	470	1,500
MD305D-15ERW	5	4.5 - 9.0	650	40	±15.0	±83	±4.0	77	30.0	330	1,500
MD312S-03ERW	12	9.0 - 18.0	282	20	3.3	758	38.0	74	30.0	2,700	750
MD312S-05ERW	12	9.0 - 18.0	329	20	5.0	600	30.0	76	30.0	2,200	750
MD312S-12ERW	12	9.0 - 18.0	305	20	12.0	250	13.0	82	30.0	680	750
MD312S-15ERW	12	9.0 - 18.0	302	20	15.0	200	10.0	83	30.0	470	750
MD312D-05ERW	12	9.0 - 18.0	321	20	±5.0	±300	±15.0	78	30.0	1,000	750
MD312D-12ERW	12	9.0 - 18.0	317	20	±12.0	±125	±6.0	79	30.0	470	750
MD312D-15ERW	12	9.0 - 18.0	313	20	±15.0	±100	±5.0	80	30.0	330	750
MD324S-03ERW	24	18.0 - 36.0	141	7	3.3	758	38.0	74	110.0	2,700	350
MD324S-05ERW	24	18.0 - 36.0	155	7	5.0	600	30.0	81	110.0	2,200	350
MD324S-09ERW	24	18.0 - 36.0	151	7	9.0	333	17.0	83	110.0	1,000	350
MD324S-12ERW	24	18.0 - 36.0	151	7	12.0	250	13.0	83	110.0	680	350
MD324S-15ERW	24	18.0 - 36.0	151	7	15.0	200	10.0	83	110.0	470	350
MD324S-24ERW	24	18.0 - 36.0	151	7	24.0	125	6.0	83	110.0	330	350
MD324D-05ERW	24	18.0 - 36.0	158	7	±5.0	±300	±15.0	79	110.0	1,000	350
MD324D-12ERW	24	18.0 - 36.0	151	7	±12.0	±125	±6.0	83	110.0	470	350
MD324D-15ERW	24	18.0 - 36.0	151	7	±15.0	±100	±5.0	83	110.0	330	350
MD348S-05ERW	48	36.0 - 75.0	82	7	5.0	600	30.0	76	45.0	2,200	200
MD348S-12ERW	48	36.0 - 75.0	78	7	12.0	250	13.0	80	45.0	680	200
MD348S-15ERW	48	36.0 - 75.0	75	7	15.0	200	10.0	84	45.0	470	200
MD348D-05ERW	48	36.0 - 75.0	79	7	±5.0	±300	±15.0	79	45.0	1,000	200
MD348D-12ERW	48	36.0 - 75.0	76	7	±12.0	±125	±6.0	82	45.0	470	200
MD348D-15ERW	48	36.0 - 75.0	76	7	±15.0	±100	±5.0	82	45.0	330	200

Notes:

- At no load, output voltage accuracy is ±1.5% typical and ±5.0% max.
- The load on dual output units should not be unbalanced more than ±5%. Units operated with unbalanced loads greater than ±5% may not meet all specifications.
- When measuring output ripple & noise, it is recommended that an external capacitor (100 µF typ.) be placed from the +Vout to the -Vout pins for single output units and from each output to common for dual output models. The maximum output ripple specified for model MD324S-05ERW is 65 mV.
- Transient recovery is measured to within a 1% error band for a load step change of 25%.
- With the addition of the DCFM-0x (or a similar discrete filter), all models will meet EN 55022 class B. A suggested input circuit is shown in the connection diagram on page 3. Contact the factory for more information.
- To meet the requirements of EN 61000-4-4 (±2 kV), external components are needed. The connection diagram on page 3 shows an external input filter that would typically achieve this. With the addition of the DCFM-0x, EN 61000-4-4 (±4 kV) can be achieved. Contact the factory for more information.
- To meet the requirements of EN 61000-4-5 (±2 kV), external components are needed. This can be done discretely (as shown in the connection diagram on page 3), or with the addition of the DCFM-0x. Contact the factory for more information.
- These units should not be operated with a load under 5% of full load. Operation at no-load will not damage the unit, but they may not meet all specifications.
- It is recommended that a fuse be used on the input of a power supply for protection. See the Model Selection table above for the correct rating.

The MD300x-ERW may be started or shutdown by the control pin input (pin 3). This input is current controlled. The unit operates when this input is open. When the input is "high" (current is flowing into the pin), the converter shuts down. The input current to this pin should be kept between 5 mA to 10 mA. Exceeding 20 mA on this input or connecting it directly to ground could damage the converter.

The diagram at right gives a suggested input circuit for the control pin. The diode (D1) is an RB160M-60/1A and Cd is a 47 nF/100V. The resistor R1 is determined by the formula:

$$R = [(Vc - Vd - 1.0)/Ic] - 300$$

Where: Vc = voltage to ground from pin 3

Vd = the forward conduction voltage drop of D1

Ic = the control pin current (5 - 10 mA)

Derating Curve

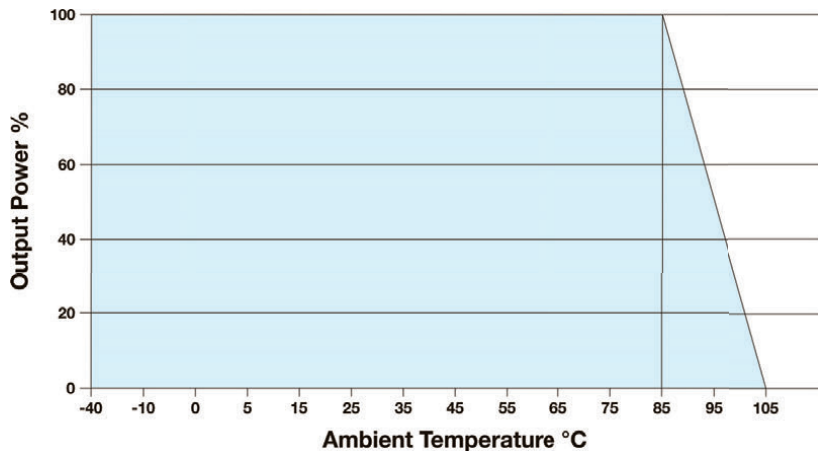

Remote ON/OFF Control

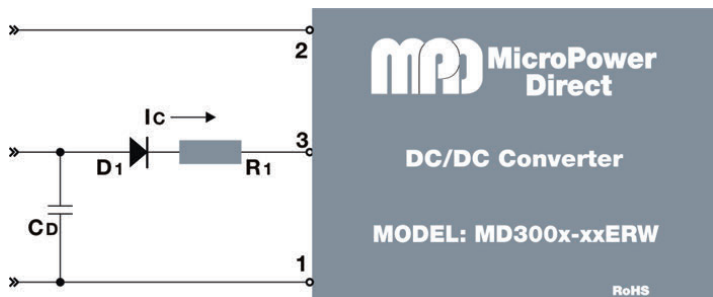

## Typical Connection

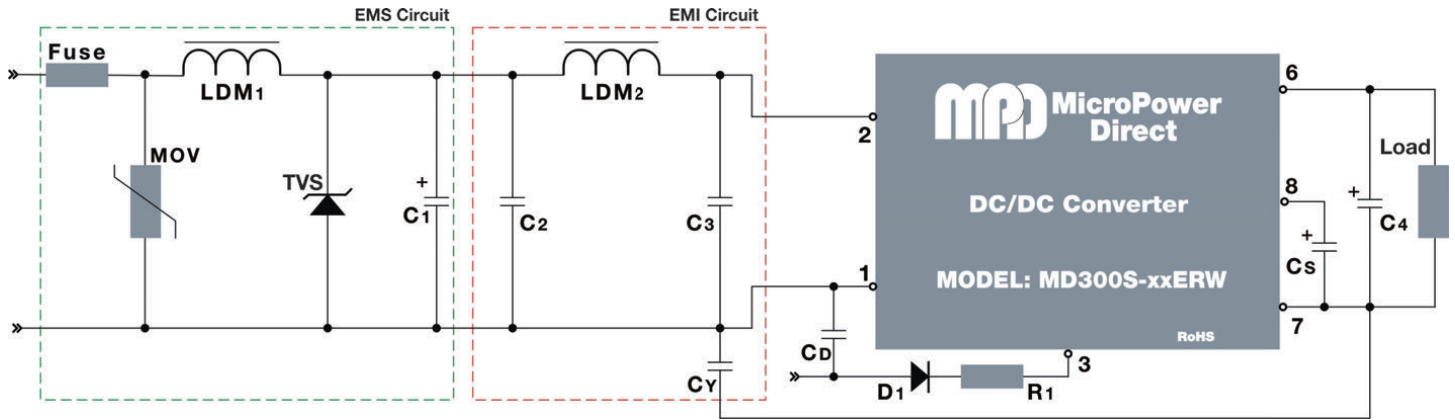

For applications that require meeting EMC standards, the diagram above illustrates a typical connection of the MD300xERW series. The units do not require external components to operate as specified. Some notes on this diagram (starting with the input circuit) are:

1. An external fuse should be used in all power module applications. The recommended fuse is shown in the model chart on page 2.
2. To protect against a surge, an external MOV is recommended on the input. A suggested value is given in the table at right.
3. To protect against voltage spikes, it is recommended that a TVS be used on the input. A suggested value is given in the table at right.
4. The capacitor C<sub>s</sub> is required to meet all specifications on single output units.
5. The output filtering capacitor (C<sub>4</sub>) is a high frequency, low resistance electrolytic capacitor. Care must be taken in choosing this capacitor not to exceed the capacitive load specification for the unit. Voltage derating of capacitors should be 80% or above.

6. Recommended values for components are:

Component	5 V <sub>IN</sub>	12 V <sub>IN</sub>	24 V <sub>IN</sub>	48 V <sub>IN</sub>
MOV	---	---	S14K35	S14K60
LDM <sub>1</sub>	---	---	56 μH	56 μH
TVS	SMCJ13A	SMCJ28A	SMCJ48A	SMCJ90A
C <sub>1</sub>	680 μF/16V	680 μF/25V	330 μF/50V	330 μF/100V
C <sub>2</sub>	4.7 μF/50V	4.7 μF/50V	4.7 μF/50V	4.7 μF/100V
LDM <sub>2</sub>	12 μH	12 μH	12 μH	12 μH
C <sub>3</sub>	4.7 μF/50V	4.7 μF/50V	4.7 μF/50V	4.7 μF/100V
CY	1nF/2 kV	1nF/2 kV	1nF/2 kV	1nF/2 kV
C <sub>s</sub>	10 μF - 22 μF			
C <sub>4</sub>	100 μF	100 μF	100 μF	100 μF

7. The drawings below show typical board layouts for the EMC/EMI circuit shown above (one for single output models and one for dual output units).

8. In many applications simply adding input/output capacitors will enhance the input surge protection and reduce output ripple sufficiently. The value of the input capacitor can range from 10 μF to 100 μF, depending on the needs of the application. The output capacitor would typically be 100 μF.
9. The capacitor C<sub>s</sub> provides additional output filtering. If used, a value of 10 μF to 20 μF is recommended. This capacitor is not required for specified operation.

## Typical Board Layout: With External Filter/Surge Components for Single Output Unit

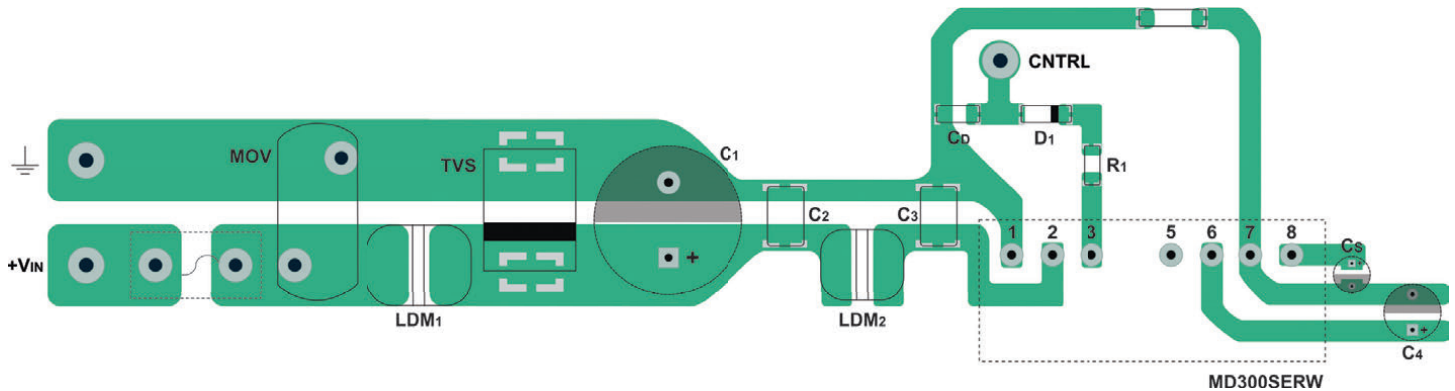

## Typical Board Layout: With External Filter/Surge Components for Dual Output Unit

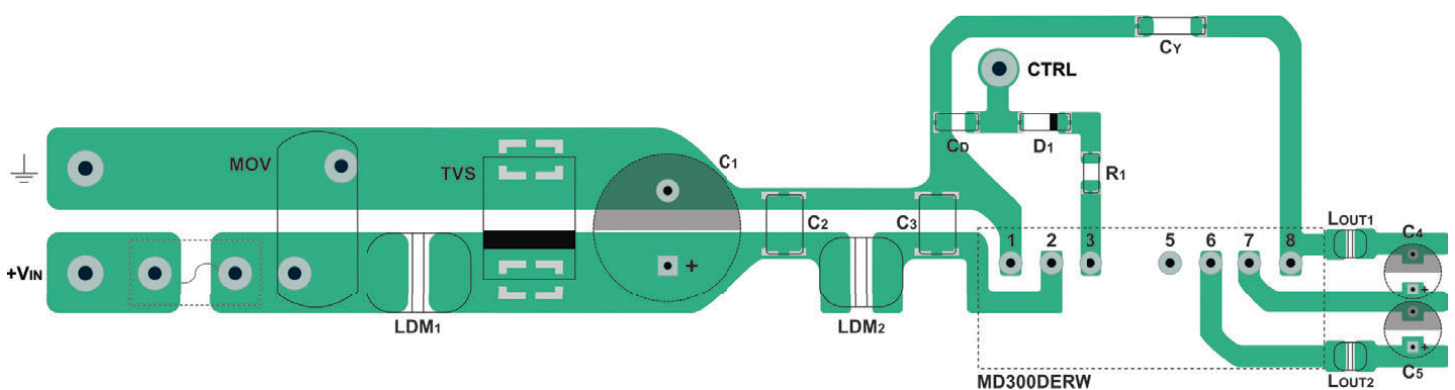

Input noise and surge suppression modules are available for a number of MPD DC/DC power supplies. An MD300xERW connection with the DCFM-02 (noise suppression) module connected to the input is shown in the diagrams below.

The recommended input capacitor (C1) is a 330  $\mu$ F/50V for 5, 12, and 24 VDC input models and 330  $\mu$ F/100V for 48 VDC input units. The output capacitors (C2 & C3) are 100  $\mu$ F. For pricing or full technical information on these modules (DCFM-01, DCFM-02 and DCFM-03) please contact the factory.

**Typical Connection: With DCFM-02 Surge Suppression and Filter Modules, Single Output**

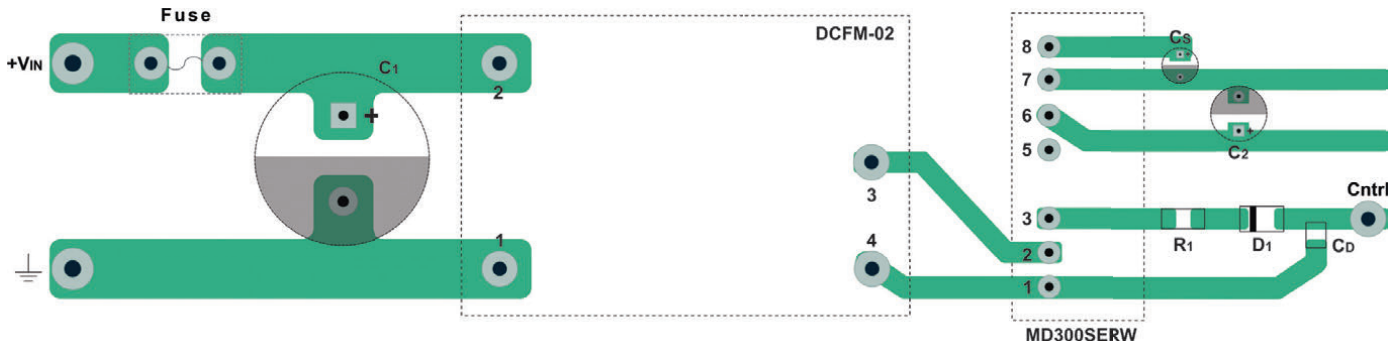

**Typical Connection: With DCFM-02 Surge Suppression and Filter Modules, Dual Output**

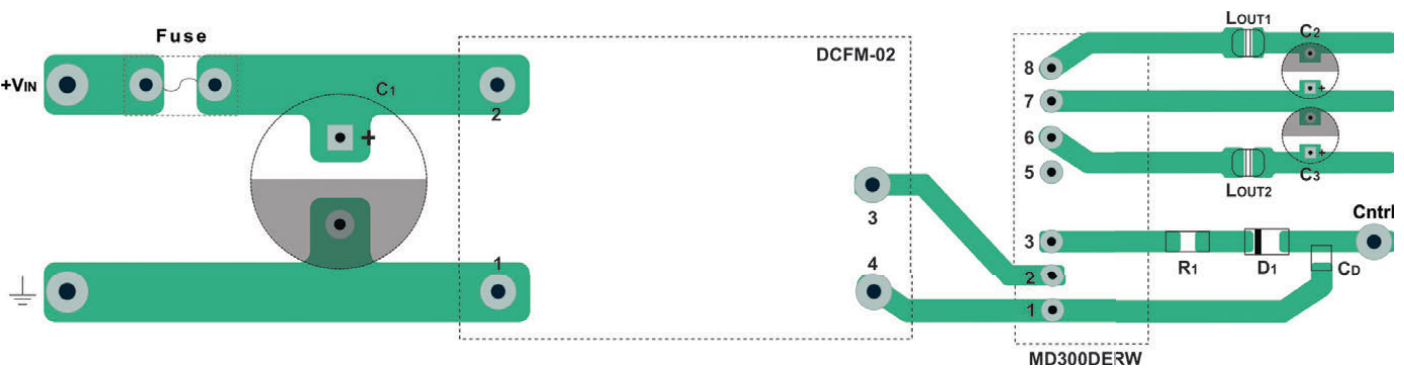

**Mechanical Dimensions**

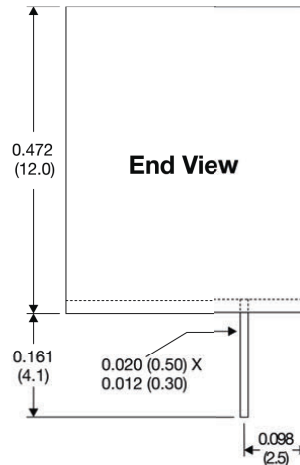
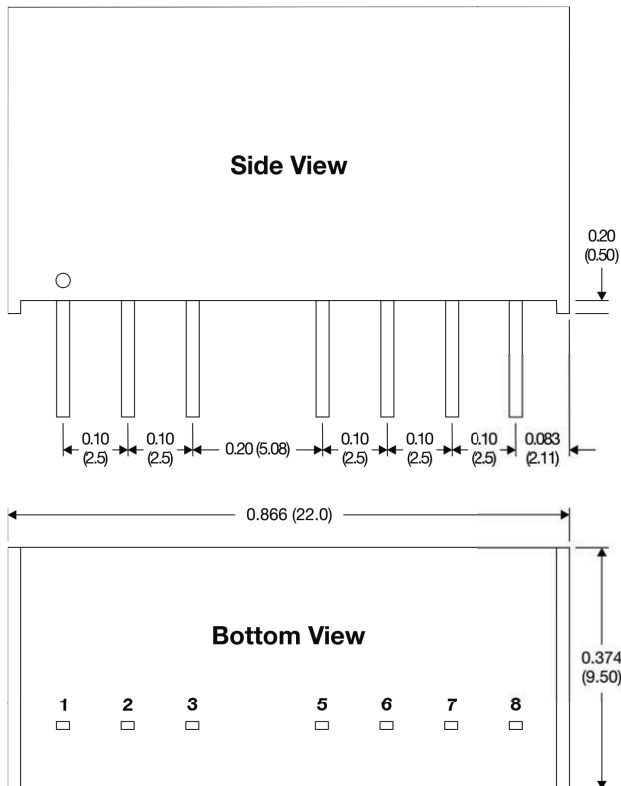

**Pin Connections**

Pin	Single Output
1	-VIN
2	+VIN
3	Remote On/Off
5	No Connection
6	+VOUT
7	-VOUT
8	CS

Pin	Dual Output
1	-VIN
2	+VIN
3	Remote On/Off
5	No Connection
6	+VOUT
7	Common
8	-VOUT

**Notes:**

- All dimensions are typical in inches (mm)
- Pin Section Tolerance x.xxx =  $\pm 0.004$  ( $\pm 0.100$ )
- General Tolerance x.xx =  $\pm 0.01$  ( $\pm 0.25$ )
- Pin 1 is marked by a "dot" or indentation on the top of the unit



**MicroPower Direct**  
We Power Your Success - For Less!